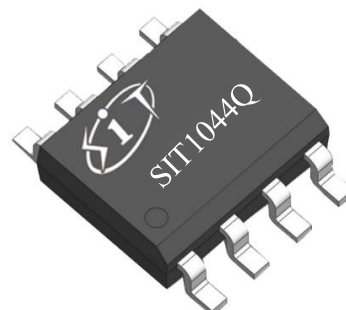

FEATURES

- Compatible with the ISO 11898 and SAE J2284-1 to SAE J2284-5 standard
- AEC-Q100 qualified
- Thermally protected
- $\pm 40V$ BUS Protection
- Transmit Data (TXD) dominant time-out function
- Low-power standby mode with wake-up function
- SIT1044QT/3 and SIT1044QTK/3 can be interfaced directly to microcontrollers with supply voltages from 3.3V to 5V
- Under-voltage protection
- Timing guaranteed for data rates up to 5 Mbps in the CAN FD fast phase
- Very low ElectroMagnetic Emission (EME)
- Transceiver in unpowered state disengages from the bus (zero load)
- The typical loop delay from TXD to RXD is less than 100ns
- Provide SOP8 and DFN3*3-8 packages

PRODUCT APPEARANCE

Provide Green and Environmentally
Friendly Lead-free package

DESCRIPTION

SIT1044Q is an interface chip used between the CAN protocol controller and the physical bus. It can be used in in-vehicle, industrial control and other fields. It supports 5Mbps (CAN FD) flexible data rate, and has a connection between the bus and the CAN protocol controller. The ability to perform differential signal transmission between the bus and the CAN protocol controller.

PARAMETER	SYMBOL	CONDITION	MIN.	MAX.	UNIT
Supply voltage	VCC		4.75	5.25	V
VIO voltage	VIO		2.95	5.25	V
Maximum transmission rate	$1/t_{bit}$	Non-return to zero code		5	Mbaud
CANH/CANL input or output voltage	V_{can}		-40	+40	V
Bus differential voltage	V_{diff}		1.5	3.0	V
Virtual junction temperature	T_j		-40	150	°C

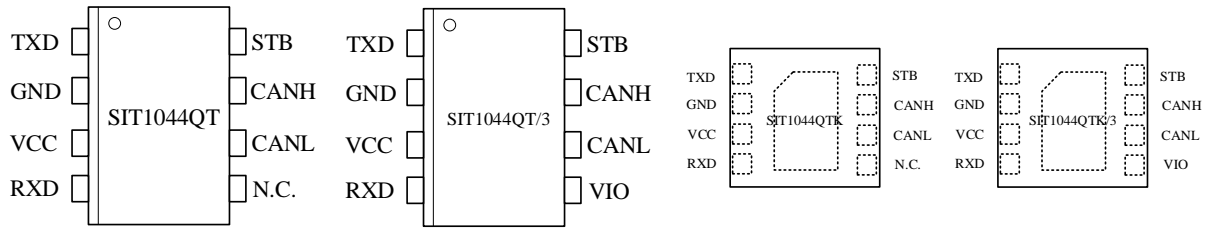
PIN CONFIGURATION

PIN DESCRIPTION

PIN	SYMBOL	DESCRIPTION
1	TXD	transmit data input
2	GND	ground
3	VCC	supply voltage
4	RXD	receive data output; reads out data from the bus lines
5	VIO	transceiver I/O level conversion power supply voltage (SIT1044QT/3, SIT1044QTK/3)
5	N.C.	not connected (SIT1044QT, SIT1044QTK)
6	CANL	LOW-level CAN bus line
7	CANH	HIGH-level CAN bus line
8	STB	standby mode control input

Note: The metal pad on the back of the DFN3*3-8 package is recommended to be grounded.

LIMITING VALUES

PARAMETER	SYMBOL	VALUE	UNIT
Supply voltage	VCC	-0.3~+7	V
MCU side port	TXD, RXD, STB, VIO	-0.3~+7	V
Bus side input voltage	CANL, CANH	-40~+40	V
Bus differential breakdown voltage	$V_{CANH-CANL}$	-27~27	V
Storage temperature	T_{stg}	-55~150	°C
Virtual junction temperature	T_j	-40~150	°C
Ambient temperature	T_A	-40~125	°C
Welding temperature range		300	°C
Continuous power consumption	SOP8	400	mW

The maximum limit parameters mean that exceeding these values may cause irreversible damage to the device. Under these conditions, it is not conducive to the normal operation of the device. The continuous operation of the device at the maximum allowable rating may affect the reliability of the device. The reference point for all voltages is ground.

DRIVER ELECTRICAL CHARACTERISTICS

PARAMETER	SYMBOL	CONDITION	MIN.	TYP.	MAX.	UNIT
CANH dominant output voltage	$V_{OH(D)}$	TXD=0V, STB=0V, $R_L=50\Omega$ to 65Ω , Fig.1 , Fig.2	2.75	3.5	4.5	V
CANL dominant output voltage	$V_{OL(D)}$		0.5	1.5	2.25	V
Bus dominant differential output voltage	$V_{OD(D)}$	TXD=0V, STB=0V, $t < t_{dom_TXD}$				
		$R_L=50\Omega$ to 65Ω	1.5		3	V
		$R_L=45\Omega$ to 70Ω	1.4		3.3	
		$R_L=2240\Omega$	1.5		5	
Bus recessive differential output voltage	$V_{OD(R)}$	TXD=VIO, STB=VIO, no load	-0.2		0.2	V
		TXD=VIO, STB=0V, no load	-0.5		0.05	V
Bus recessive output voltage	$V_{O(R)}$	STB=0V; TXD=VIO; no load	2	0.5VCC	3	V
		STB=VIO; no load	-0.1		0.1	
Transmitter dominant voltage symmetry	$V_{dom(TX)sym}$	$V_{dom(TX)sym}=VCC - V_{CANH} - V_{CANL}$	-400		400	mV
Transmitter voltage symmetry	V_{TXsym}	$V_{TXsym}=CANH+CANL$ ⁽¹⁾ ; $f_{TXD}=250kHz, 1MHz$ or $2.5MHz$; $C_{SPLIT}=4.7nF$, Fig.7	0.9VCC		1.1VCC	V
Common-mode output voltage	V_{OC}	STB=0V, Fig.2	2	0.5VCC	3	V
Dominant short-circuit output current	I_{OS_dom}	VTXD=0V; $t < t_{dom_TXD}$; VCC=5V				
		Pin CANH; CANH= -15V to 40V	-100		100	mA
		Pin CANL; CANL= -15V to 40V	-100		100	mA
Recessive short-circuit output current	$I_{O(R)}$	TXD=VIO; $-27V < CANH=CANL < 32V$	-5		5	mA

(1) Not tested in production; guaranteed by design.

(VCC=5V±5% and $T_j=-40^\circ C \sim 150^\circ C$ unless specified otherwise; typical in VCC=+5V, VIO=+5V and $T_A=25^\circ C$).

DRIVER SWITCHING CHARACTERISTICS

PARAMETER	SYMBOL	CONDITION	MIN.	TYP.	MAX.	UNIT
Driver timing; pins CANH, CANL, RXD; see Fig.3 and Fig.5 and Fig.6 ; $R_L=60\Omega$; $C_L=100\text{pF}$; $C_{RXD}=15\text{pF}$.						
Propagation delay time, TXD to bus recessive	$t_{d(\text{TXD_busrec})}$	STB=0V, Fig.3 , Fig.6		90		ns
Propagation delay time, TXD to bus dominant	$t_{d(\text{TXD_busdom})}$	STB=0V, Fig.3 , Fig.6		65		ns
Differential output signal rise time	t_r	STB=0V, Fig.3 , Fig.6		45		ns
Differential output signal fall time	t_f	STB=0V, Fig.3 , Fig.6		45		ns
Enable time from standby mode to dominant	$t_{\text{stb_nom}}$			10	45	μs
TXD dominant time-out	$t_{\text{dom_TXD}}$	Fig.4	0.8	3	6.5	ms
Bus dominant time-out time	$t_{\text{filter_WAKE}}$	standby, Fig.8	0.5		1.8	μs
Bus wake-up filter time	$t_{\text{dom_WAKE}}$	standby, Fig.8	0.8	3	6.5	ms

($V_{CC}=5\text{V}\pm 5\%$ and $T_j=-40^\circ\text{C}\sim 150^\circ\text{C}$ unless specified otherwise; typical in $V_{CC}=+5\text{V}$, $V_{IO}=+5\text{V}$ and $T_A=25^\circ\text{C}$).

RECEIVER ELECTRICAL CHARACTERISTICS

PARAMETER	SYMBOL	CONDITION	MIN.	TYP.	MAX.	UNIT
Positive-going input threshold voltage	$V_{\text{TH+_dif}}$	Normal mode; $-12\text{V}\leq V_{\text{CANL}}\leq +12\text{V}$; $-12\text{V}\leq V_{\text{CANH}}\leq +12\text{V}$;			900	mV
Negative-going input threshold voltage	$V_{\text{TH-_dif}}$	Normal mode; $-12\text{V}\leq V_{\text{CANL}}\leq +12\text{V}$; $-12\text{V}\leq V_{\text{CANH}}\leq +12\text{V}$;	500			mV
Hysteresis voltage ($V_{\text{TH+_dif}}-V_{\text{TH-_dif}}$)	V_{HYS}	Normal mode; $-12\text{V}\leq V_{\text{CANL}}\leq +12\text{V}$; $-12\text{V}\leq V_{\text{CANH}}\leq +12\text{V}$;		120		mV

PARAMETER	SYMBOL	CONDITION	MIN.	TYP.	MAX.	UNIT
Positive-going input threshold voltage	V_{TH+_dif}	Standby mode; $-12\text{ V} \leq V_{CANL} \leq +12\text{ V}$; $-12\text{ V} \leq V_{CANH} \leq +12\text{ V}$;			1150	mV
Negative-going input threshold voltage	V_{TH-_dif}	Standby mode; $-12\text{ V} \leq V_{CANL} \leq +12\text{ V}$; $-12\text{ V} \leq V_{CANH} \leq +12\text{ V}$;	400			mV
Receiver dominant differential input voltage	V_{dom_Diff}	Normal mode; $-12\text{ V} \leq V_{CANL} \leq +12\text{ V}$; $-12\text{ V} \leq V_{CANH} \leq +12\text{ V}$;	0.9		8.0	V
		Standby mode; $-12\text{ V} \leq V_{CANL} \leq +12\text{ V}$; $-12\text{ V} \leq V_{CANH} \leq +12\text{ V}$;	1.15		8.0	V
Receiver recessive differential input voltage	V_{rec_Diff}	Normal mode; $-12\text{ V} \leq V_{CANL} \leq +12\text{ V}$; $-12\text{ V} \leq V_{CANH} \leq +12\text{ V}$;	-3		0.5	V
		Standby mode; $-12\text{ V} \leq V_{CANL} \leq +12\text{ V}$; $-12\text{ V} \leq V_{CANH} \leq +12\text{ V}$;	-3		0.4	V
Power-off bus input current	$I_{(OFF)}$	$CANH=CANL=5\text{V}$, $GND=VCC=VIO=0\text{V}$	-5		5	μA
Input capacitance to ground, (CANH or CANL)	C_I	(1)			24	pF
Differential input capacitance	C_{ID}	(1)			12	pF
Slew Rate	SR	Edge dominant to recessive (1)			70	V/ μs
Input resistance, (CANH or CANL)	R_{IN}	$TXD=VIO$, $STB=0\text{V}$; (1) $-2\text{ V} \leq V_{CANL} \leq +7\text{ V}$;	9	15	28	k Ω
Differential input resistance	R_{ID}	$-2\text{ V} \leq V_{CANH} \leq +7\text{ V}$;	19	30	52	k Ω
Input resistance matching	R_{I_match}	$CANH=CANL$; (1) $0\text{ V} \leq V_{CANL} \leq +5\text{ V}$; $0\text{ V} \leq V_{CANH} \leq +5\text{ V}$;	-2		2	%
The range of common-mode voltage	V_{COM}		-12		12	V

(1) Not tested in production; guaranteed by design.

(VCC=5V \pm 5% and T_j=-40°C~150°C unless specified otherwise; typical in VCC=+5V, VIO=+5V and T_A=25°C).

RECEIVER SWITCHING CHARACTERISTICS

PARAMETER	SYMBOL	CONDITION	MIN.	TYP.	MAX.	UNIT
Receive timing; pins CANH, CANL, RXD; see Fig.3 and Fig.5 and Fig.6 ; $R_L=60\Omega$; $C_L=100pF$; $C_{RXD}=15pF$.						
Propagation delay time, bus recessive to RXD	$t_{d(busrec_RXD)}$	STB=0V, Fig.3 , Fig.6		65		ns
Propagation delay time, bus dominant to RXD	$t_{d(busdom_RXD)}$	STB=0V, Fig.3 , Fig.6		60		ns
RXD signal rise time	t_r	STB=0V, Fig.3 , Fig.6		10		ns
RXD signal fall time	t_f	STB=0V, Fig.3 , Fig.6		10		ns

($V_{CC}=5V\pm 5\%$ and $T_j=-40^\circ C\sim 150^\circ C$ unless specified otherwise; typical in $V_{CC}=+5V$, $V_{IO}=+5V$ and $T_A=25^\circ C$).

DEVICE SWITCHING CHARACTERISTICS

PARAMETER	SYMBOL	CONDITION	MIN.	TYP.	MAX.	UNIT
Transceiver timing; pins CANH, CANL, TXD and RXD; see Fig.3 and Fig.5 and Fig.6 ; $R_L=60\Omega$; $C_L=100pF$; $C_{RXD}=15pF$.						
Loop delay 1, driver input to receiver output, Recessive to Dominant	t_{loop1}	STB=0V, Fig.3 , Fig.6		80	220	ns
Loop delay 2, driver input to receiver output, Dominant to Recessive	t_{loop2}	STB=0V, Fig.3 , Fig.6		90	220	ns
Bit time of BUS output pin	$t_{bit(BUS)}$	$t_{bit(TXD)}=500ns^{(1)}$, Fig.5 , Fig.6	435		530	ns
		$t_{bit(TXD)}=200ns^{(2)}$, Fig.5 , Fig.6	155		210	ns
Bit time of RXD output pin	$t_{bit(RXD)}$	$t_{bit(TXD)}=500ns^{(1)}$, Fig.5 , Fig.6	400		550	ns
		$t_{bit(TXD)}=200ns^{(2)}$, Fig.5 , Fig.6	120		220	ns
Receiver timing symmetry	Δt_{rec}	$t_{bit(TXD)}=500ns^{(1)}$, Fig.5 , Fig.6	-65		+40	ns

PARAMETER	SYMBOL	CONDITION	MIN.	TYP.	MAX.	UNIT
Receiver timing symmetry		$t_{bit(TXD)}=200ns^{(2)}$, Fig.5 , Fig.6	-45		+15	ns

(1) Transmitted recessive bit width at 2Mbit/s.

(2) Transmitted recessive bit width at 5Mbit/s.

(VCC=5V±5% and T_j=-40°C~150°C unless specified otherwise; typical in VCC=+5V, VIO=+5V and T_A=25°C).

OVER TEMPERATURE PROTECTION

PARAMETER	SYMBOL	CONDITION	MIN.	TYP.	MAX.	UNIT
Shutdown junction temperature	T _{j(sd)}			190		°C

(VCC=5V±5% and T_j=-40°C~150°C unless specified otherwise; typical in VCC=+5V, VIO=+5V and T_A=25°C).

UNDER-VOLTAGE PROTECTION

PARAMETER	SYMBOL	CONDITION	MIN.	TYP.	MAX.	UNIT
VCC under-voltage protection	V _{uvd_VCC}		3.5	3.9	4.3	V
VIO under-voltage protection	V _{uvd_VIO}		2.1	2.5	2.7	V

(VCC=5V±5% and T_j=-40°C~150°C unless specified otherwise; typical in VCC=+5V, VIO=+5V and T_A=25°C).

TXD PIN CHARACTERISTICS

PARAMETER	SYMBOL	CONDITION	MIN.	TYP.	MAX.	UNIT
HIGH-level input current	I _{IH(TXD)}	TXD=VIO	-5		5	μA
LOW-level input current	I _{IL(TXD)}	TXD=0V	-260	-150	-30	μA
When VCC=0V, current on TXD pin	I _{o(off)}	VCC=VIO=0V, TXD=VIO	-1		1	μA
HIGH-level input voltage	V _{IH}		0.7V _{IO} ⁽¹⁾		V _{IO} ⁽¹⁾ +0.3	V
LOW-level input voltage	V _{IL}		-0.3		0.3V _{IO} ⁽¹⁾	V

PARAMETER	SYMBOL	CONDITION	MIN.	TYP.	MAX.	UNIT
Open voltage on TXD pin	TXD _O			H		logic

(1) SIT1044QT and SIT1044QTK model V_{IO}=V_{CC}.

(V_{CC}=5V±5% and T_j=-40°C~150°C unless specified otherwise; typical in V_{CC}=+5V, V_{IO}=+5V and T_A=25°C).

STB PIN CHARACTERISTICS

PARAMETER	SYMBOL	CONDITION	MIN.	TYP.	MAX.	UNIT
HIGH-level input current	I _{IH} (STB)	STB=V _{IO}	-2		2	μA
LOW-level input current	I _{IL} (STB)	STB=0V	-15		-1	μA
When V _{CC} =0V, current on STB pin	I _O (off)	V _{CC} =V _{IO} =0V, STB=V _{IO}	-1		1	μA
HIGH-level input voltage	V _{IH}		0.7V _{IO} ⁽¹⁾		V _{IO} ⁽¹⁾ +0.3	V
LOW-level input voltage	V _{IL}		-0.3		0.3V _{IO} ⁽¹⁾	V
Open voltage on STB pin	STB _O			H		logic

(1) SIT1044QT and SIT1044QTK model V_{IO}=V_{CC}.

(V_{CC}=5V±5% and T_j=-40°C~150°C unless specified otherwise; typical in V_{CC}=+5V, V_{IO}=+5V and T_A=25°C).

RXD PIN CHARACTERISTICS

PARAMETER	SYMBOL	CONDITION	MIN.	TYP.	MAX.	UNIT
HIGH-level input current	I _{O_H} (RXD)	V _{IO} =V _{CC} , RXD=V _{IO} -0.4V	-8	-3	-1	mA
LOW-level input current	I _{O_L} (RXD)	RXD=0.4V, bus dominant	1		12	mA
When V _{CC} =0V, current on STB pin	I _O (off)	V _{CC} =V _{IO} =0V, RXD=V _{IO}	-1		1	μA

(V_{CC}=5V±5% and T_j=-40°C~150°C unless specified otherwise; typical in V_{CC}=+5V, V_{IO}=+5V and T_A=25°C).

SUPPLY CURRENT

PARAMETER	SYMBOL	CONDITION	MIN.	TYP.	MAX.	UNIT
VCC current (standby mode)	I _{CC}	STB=VCC, TXD=VIO, SIT1044QT/3 or SIT1044QTK/3			5	μA
		STB=VCC, TXD=VCC, SIT1044QT or SIT1044QTK		15	30	μA
VCC current (Dominant)		TXD=VIO, STB=0V, load=60Ω		45	70	mA
VCC current (Recessive)		TXD=VIO, STB=0V, no load		5	10	mA
VIO current (standby mode)	I _{IO}	STB=TXD=VIO		14	28	μA
VIO current (Dominant)		TXD=0V, STB=0V		180	500	μA
VIO current (Recessive)		TXD=VIO, STB=0V		30	200	μA

(VCC=5V±5% and T_j=-40°C~150°C unless specified otherwise; typical in VCC=+5V, VIO=+5V and T_A=25°C).

ESD PERFORMANCE

PARAMETER	SYMBOL	CONDITION	MIN.	TYP.	MAX.	UNIT
CAN bus pin contact discharge model (IEC)	V _{ESD_IEC}	IEC 61000-4-2: Contact discharge	-4		+4	kV
CAN bus pin human body discharge model (HBM)	V _{ESD_HBM}		-8		+8	kV

FUNCTION TABLE
Table1. CAN transceiver truth table

TXD ⁽¹⁾	STB ⁽¹⁾	CANH ⁽¹⁾	CANL ⁽¹⁾	BUS STATE	RXD ⁽¹⁾
L	L	H	L	Dominate	L
H or Open	L	0.5VCC	0.5VCC	Recessive	H
X	H or Open	GND	GND	Recessive	H

(1) H=high level; L=low level; X=irrelevant.

Table 2. Receiver function table

V_{ID}=CANH-CANL	RXD ⁽¹⁾	Bus State ⁽¹⁾
$V_{ID} \geq 0.9V$	L	Dominate
$0.5 < V_{ID} < 0.9V$?	?
$V_{ID} \leq 0.5V$	H	Recessive
Open	H	Recessive

(1) H=high-level; L=low-level; ?=uncertain.

Table 3. Under-voltage protection status table

VCC	VIO ⁽¹⁾	BUS STATE	BUS OUT ⁽²⁾	RXD ⁽²⁾
$VCC > V_{uvd_VCC}$	$VIO > V_{uvd_VIO}$	normal	According to STB and TXD	Follow the bus
$VCC < V_{uvd_VCC}$	$VIO > V_{uvd_VIO}$	Protected state	GND	H
$VCC > V_{uvd_VCC}$	$VIO < V_{uvd_VIO}$	Protected state	Z	H
$VCC < V_{uvd_VCC}$	$VIO < V_{uvd_VIO}$	Protected state	Z	H

(1) Only SIT1044QT/3 and SIT1044QTK/3version;

(2) H=high level; Z=high impedance state.

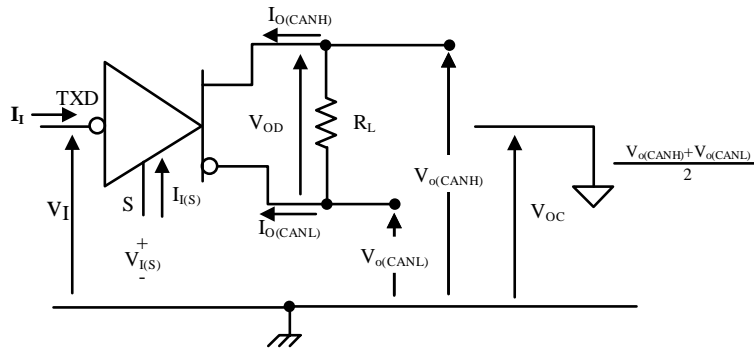
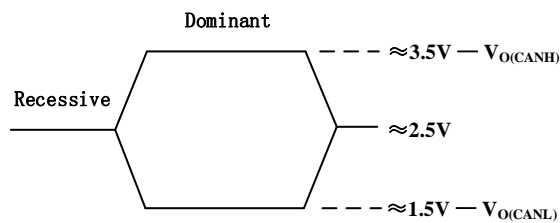
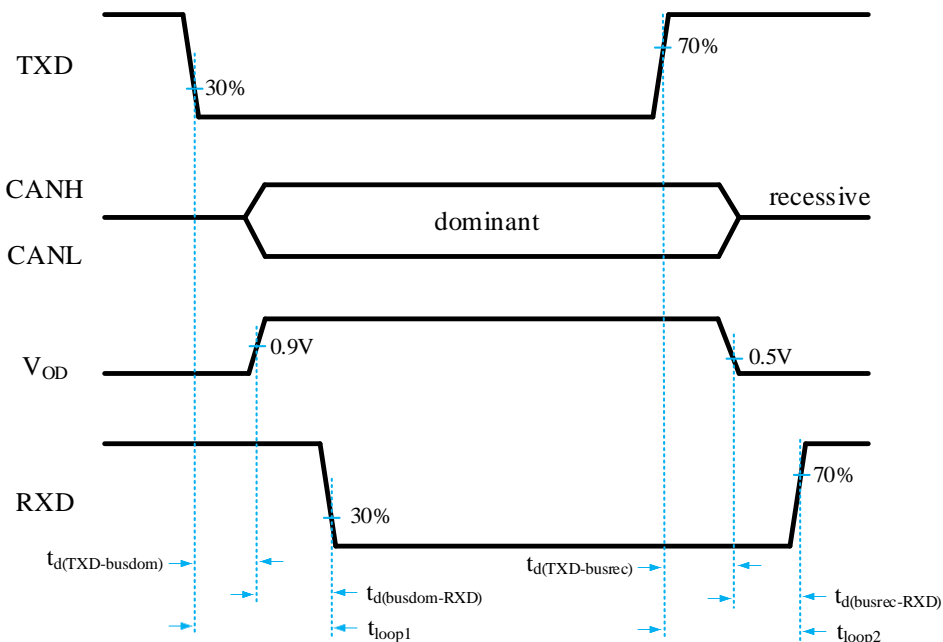
TEST CIRCUIT

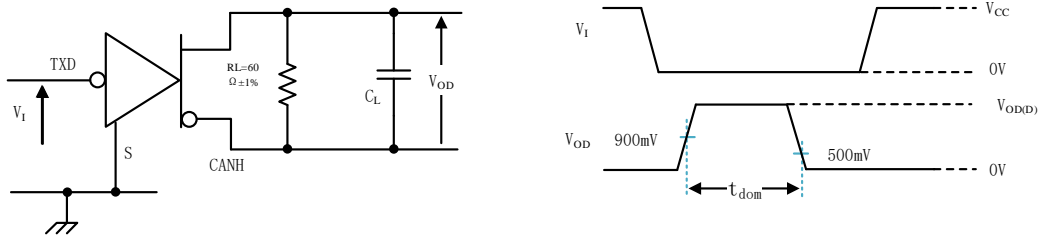
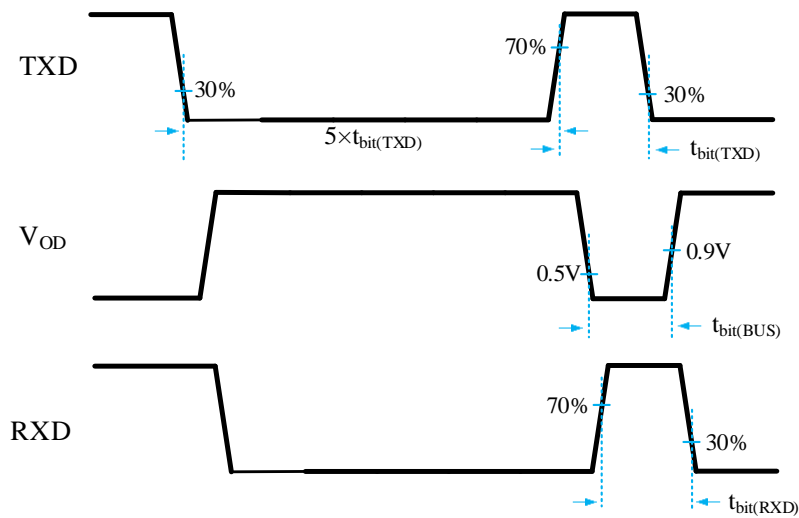
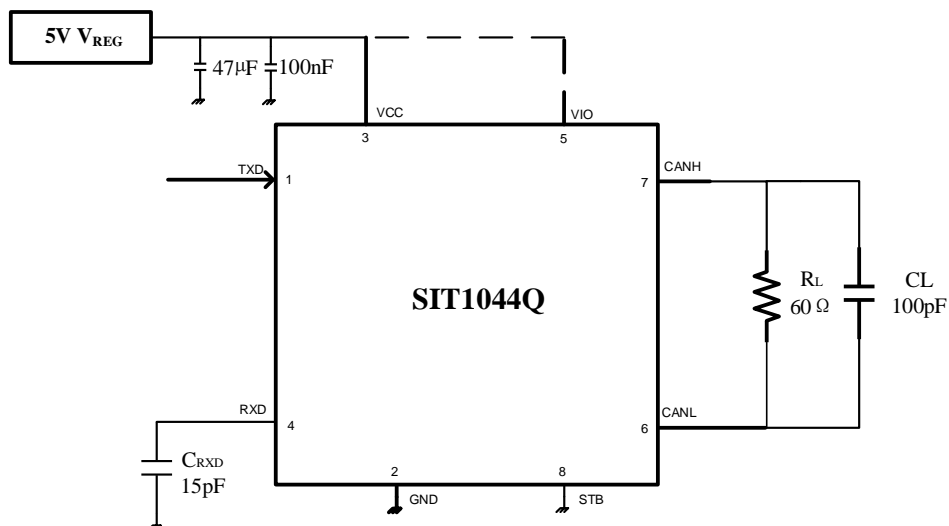
Fig.1 Driver Voltage, Current, and Test Definition

Fig.2 Bus Logic State Voltage Definition

Fig.3 Transceiver timing diagram

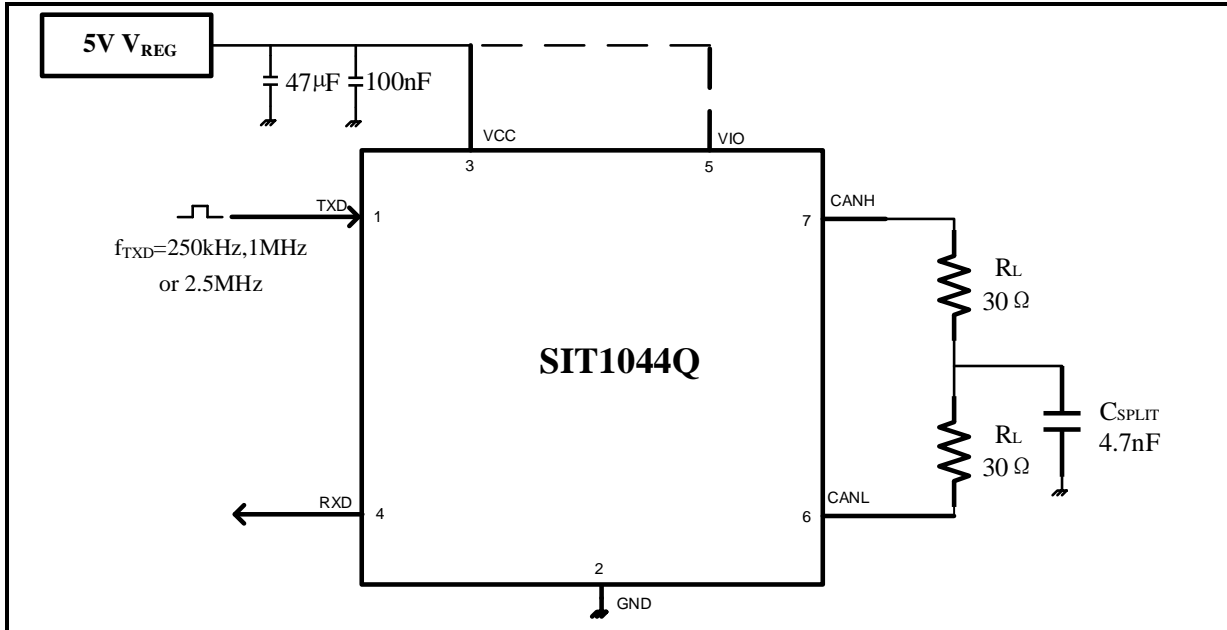
Fig.4 Dominant overtime test circuit and waveform

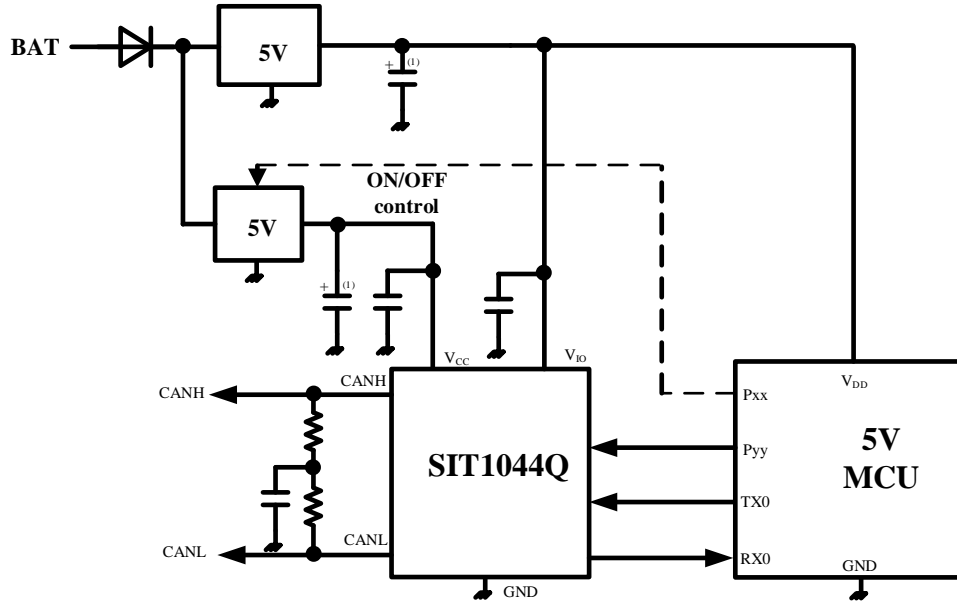
Fig.5 t_{bit} test circuit and waveform

The VIO pin is internally connected to pin VCC in the non-VIO product variants SIT1044QT and SIT1044QTK.

Fig.6 CAN transceiver timing test circuit

Fig.7 Test circuit for measuring transmitter driver symmetry

TYPICAL APPLICATION TEST INFORMATION

(1) SIT1044QT/3 and SIT1044QTK/3 can be applied to 3V or 5V MCU.

SIT1044Q typical application diagram

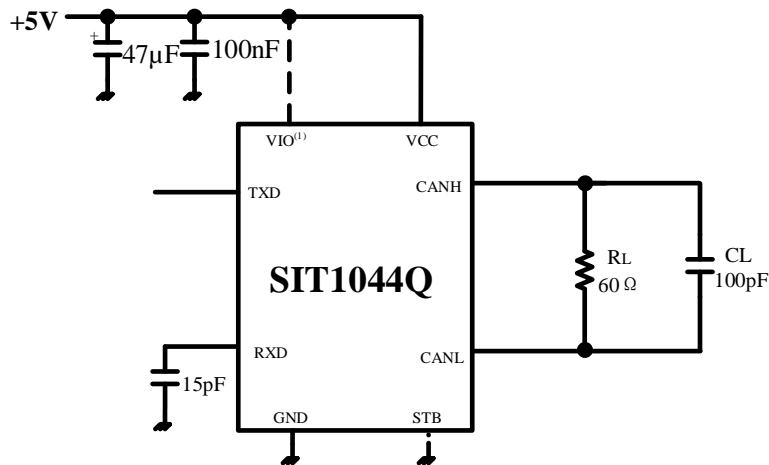

(1) V_{IO} is limited to SIT1044QT/3 and SIT1044QTK/3, V_{IO}=V_{CC} in SIT1044QT and SIT1044QTK.

SIT1044Q typical high-speed mode test chart

ADDITIONAL DESCRIPTION
1 Sketch

SIT1044Q is an interface chip applied between the CAN protocol controller and the physical bus. It can be used in in-vehicle, industrial control and other fields. It supports 5Mbps (CAN FD) flexible data rate, and has a connection between the bus and the CAN protocol controller. The ability to perform differential signal transmission between them is fully compatible with the "ISO 11898-2: 2016" standard.

2 Over temperature protection

SIT1044Q has an over-temperature protection function. After the over-temperature protection is triggered, the drive tube will be turned off, because the drive tube is the main energy-consuming component. Turning off the drive tube can reduce power consumption and thus reduce the chip temperature. At the same time, other parts of the chip are still working normally.

3 Under-voltage protection

The SIT1044Q power supply pin has an under-voltage detection function, which can put the device in a protected mode. This protects the bus when VCC is lower than $V_{\text{uvd_VCC}}$ or VIO is lower than $V_{\text{uvd_VIO}}$ (if applicable).

4 Operating modes

The control pin STB allows two working modes to be selected: high-speed mode and standby mode. The high-speed mode is a normal operating mode and is selected by grounding the pin STB. Both the CAN driver and the receiver can operate normally and CAN communication is carried out in both directions. Pin STB set to high level or VCC undervoltage (SIT1044QT/3), and the standby module will detect the signal on the bus. When complete dominant-recessive-dominant pattern within $t_{\text{dom_WAKE}}$ to be recognized as a valid wake up pattern (see [Fig.8](#)). Otherwise, the internal wake up is reset. The complete wake up pattern will then need to be re-transmitted to trigger a wake-up event. Pin RXD remains HIGH until the wake-up event has been triggered.

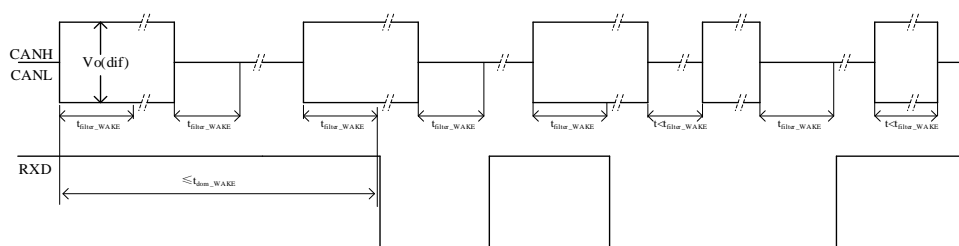
Fig.8 Wake-up timing
5 Dominant timeout function

In high-speed mode, if the low-level duration on pin TXD exceeds the internal timer value ($t_{\text{dom_TXD}}$), the transmitter will be disabled and drive the bus into a recessive state. It can prevent the pin TXD from being forced to a permanent low level due to a hardware or software application failure, causing the bus line to be driven to a permanent dominant state (blocking all network communications). A rising edge signal on pin TXD can be reset.

SOP8 DIMENSIONS
PACKAGE SIZE

SYMBOL	MIN./mm	TYP./mm	MAX./mm
A	1.40	-	1.80
A1	0.10	-	0.25
A2	1.30	1.40	1.50
A3	0.60	0.65	0.70
b	0.38	-	0.51
D	4.80	4.90	5.00
E	5.80	6.00	6.20
E1	3.80	3.90	4.00
e	1.27BSC		
h	0.25	-	0.50
L	0.40	0.60	0.80
L1	1.05REF		
c	0.20	-	0.25
θ	0°	-	8°

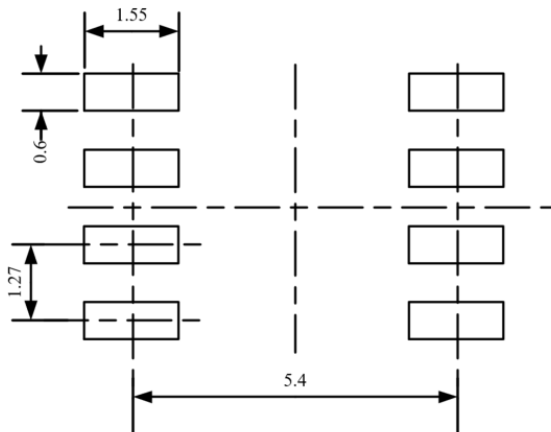
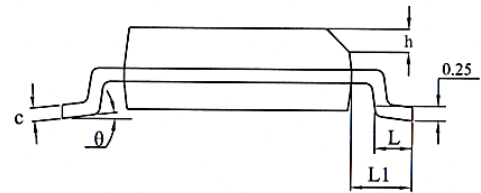
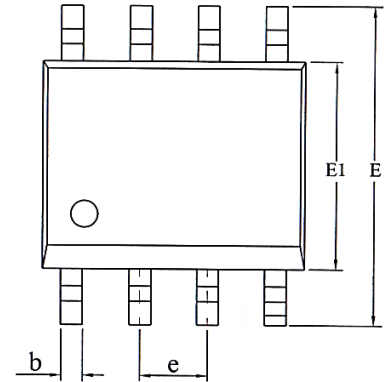

LAND PATTERN EXAMPLE (Unit: mm)

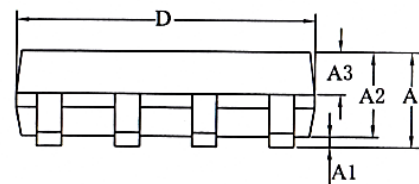

DFN3*3-8 DIMENSIONS
PACKAGE SIZE

SYMBOL	MIN/mm	TYP /mm	MAX/mm
A	0.70	0.75	0.80
A1	0	0.02	0.05
c	0.203 REF		
D	2.90	3.00	3.10
E	2.90	3.00	3.10
D2	2.05	2.15	2.25
Nd	1.95BSC		
E2	1.10	1.20	1.30
b	0.25	0.30	0.35
e	0.65 TYP		
k	0.50REF		
L	0.35	0.4	0.45
h	0.20	0.25	0.30

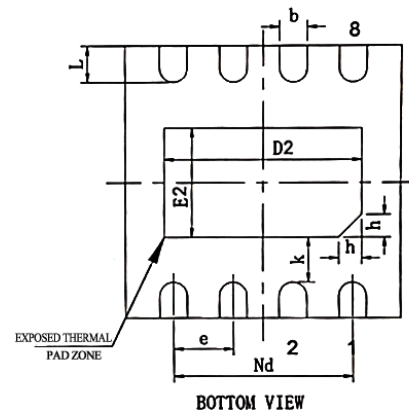
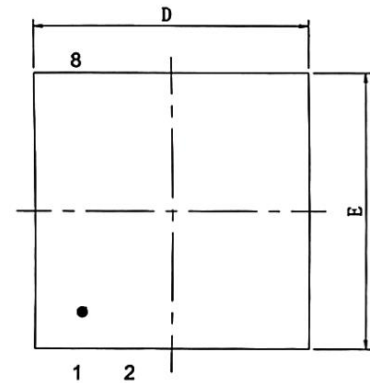
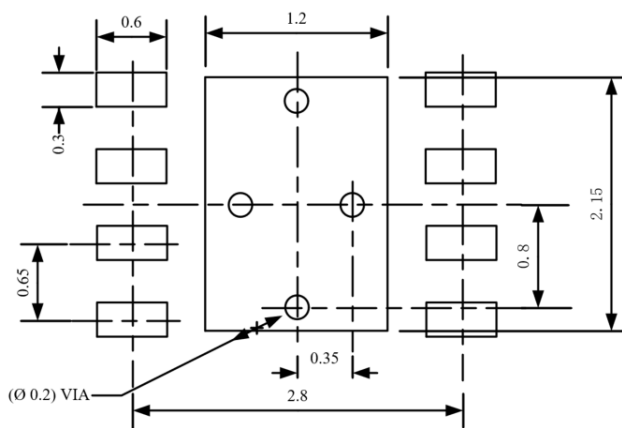
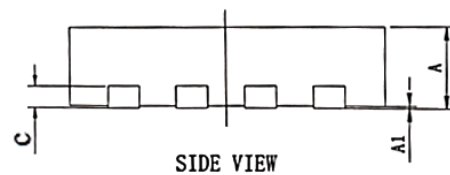
BOTTOM VIEW

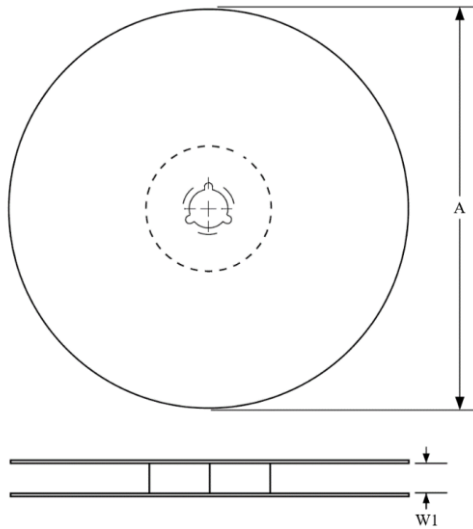
LAND PATTERN EXAMPLE (Unit: mm)

SIDE VIEW

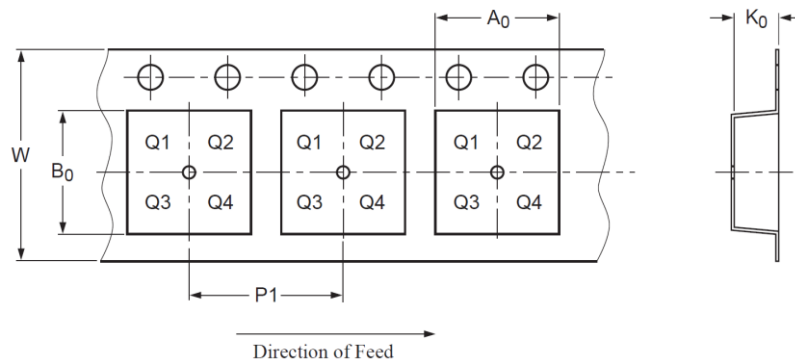
TAPE AND REEL INFORMATION

A0	Dimension designed to accommodate the component width
B0	Dimension designed to accommodate the component length
K0	Dimension designed to accommodate the component thickness
W	Overall width of the carrier tape
P1	Pitch between successive cavity centers



PIN1 is in quadrant 1

Package Type	Reel Diameter A (mm)	Reel Width W1 (mm)	A0 (mm)	B0 (mm)	K0 (mm)	P1 (mm)	W (mm)
SOP8	330±1	12.4	6.60±0.1	5.30±0.10	1.90±0.1	8.00±0.1	12.00±0.1
DFN3*3-8	329±1	12.4	3.30±0.1	3.30±0.1	1.10±0.1	8.00±0.1	12.00±0.3

ORDERING INFORMATION

TYPE NUMBER	PACKAGE	PACKING
SIT1044QT	SOP8	Tape and reel
SIT1044QT/3	SOP8	Tape and reel
SIT1044QTK	DFN3*3-8, Small shape, no leads, 8 terminals	Tape and reel
SIT1044QTK/3	DFN3*3-8, Small shape, no leads, 8 terminals	Tape and reel

SOP8 package is 2500 pieces/disc. DFN3*3-8 package is 6000 pieces/disc.

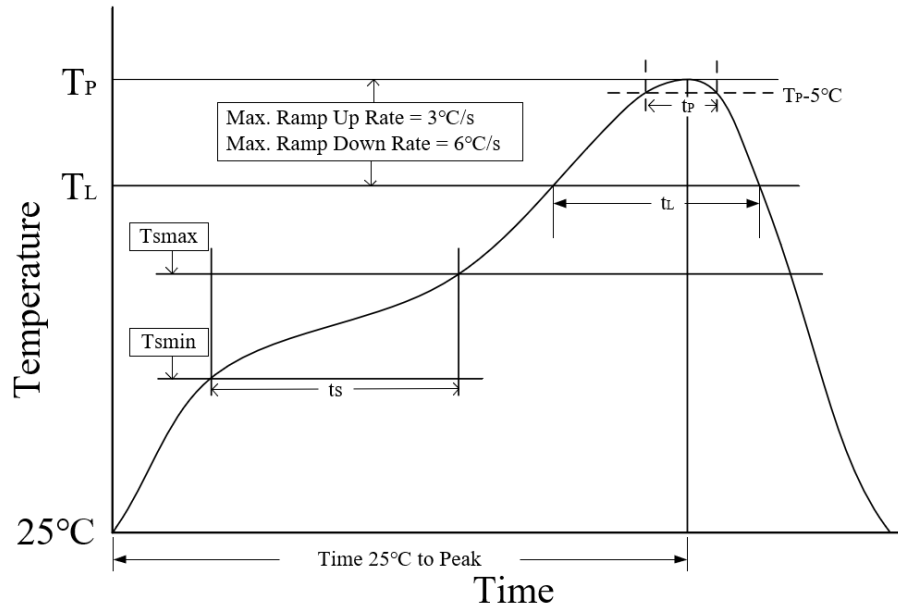
REFLOW SOLDERING

Parameter	Lead-free soldering conditions
Ave ramp up rate (T_L to T_P)	$3^\circ\text{C}/\text{second}$ max
Preheat time t_s ($T_{smin}=150^\circ\text{C}$ to $T_{smax}=200^\circ\text{C}$)	60-120 seconds
Melting time t_L ($T_L=217^\circ\text{C}$)	60-150 seconds
Peak temp T_P	$260\text{-}265^\circ\text{C}$
5°C below peak temperature t_p	30 seconds
Ave cooling rate (T_P to T_L)	$6^\circ\text{C}/\text{second}$ max
Normal temperature 25°C to peak temperature T_P time	8 minutes max

Important statement

SIT reserves the right to change the above-mentioned information without prior notice.

REVISION HISTORY

Version number	Data sheet status	Revision date
V1.0	Initial version.	April 2021
V1.1	Modified the typical value of t_{loop1} ; Modified the typical value of t_{loop2} ; Modified the VCC standby mode current of the SIT1044QT; Modified VIO standby mode current, VIO dominant current, VIO recessive current.	July 2021
V1.2	Added DFN3*3-8, small outline, leadless package; Added DFN pin diagram.	August 2021
V1.3	Added TXD and STB pin input voltage description for SIT1044QT/3.	October 2021
V1.4	Added slew rate indicator and added superscript description.	December 2021
V1.5	Modified the busbar withstand voltage index; Modified package size.	January 2022
V1.6	Added test conditions for dominant differential voltage; Added differential voltage test index; increased bus output voltage condition; increased output voltage symmetry condition; modified explicit and recessive output short-circuit current index; added superscript description; Added receiver threshold test conditions; Added dominant and recessive output differential voltage indicators; Added input differential resistor and Input resistance matching; Added receive timing condition; Added transceiver timing description conditions; Increased receive time symmetry parameter; Modified the high-level input current of the STB; Deleted the driver VOD test circuit in Figure 3, and add the transceiver timing diagram; Deleted the driver test circuit and voltage waveform diagram in Figure 4; Deleted the definition of receiver voltage and current in Figure 5; Deleted the receiver test circuit and voltage waveform in Figure 6; Deleted the common mode output voltage test and waveform in Figure 7; Deleted the t_{loop} test circuit and waveform in Figure 8; Deleted the short-circuit current test and waveform of the driver in	April 2022

Version number	Data sheet status	Revision date
	Figure 10; Added Figure 6 Transceiver Test Circuit; Added Figure 7 Transceiver Driver Symmetry Test Circuit.	
V1.7	Added revision history.	May 2022
V1.8	Added AEC-Q100 information.	June 2022
V1.9	Added module power VIO tag; Updated control mode description.	August 2022
V1.10	Added SIT1044QTK version and updated information related to SIT1044QTK.	December 2022
V1.11	Added “compatible with SAE J2284-1 to SAE J2284-5”.	April 2024