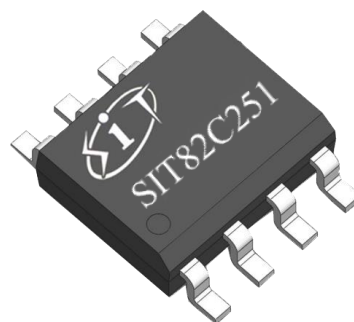

FEATURES

- Fully compatible with ISO 11898 standard
- Thermally protected
- Overcurrent protection function
- Very low-current standby mode ($<5\mu\text{A}$)
- Transceiver in unpowered state disengages from the bus (zero load)
- At least 110 nodes can be connected
- High speed (up to 1 Mbaud)
- High anti-electromagnetic interference ability

PRODUCT APPEARANCE

Provide Green and Environmentally Friendly Lead-free package

DESCRIPTION

SIT82C251 is an interface chip applied between the CAN protocol controller and the physical bus. It can be used in in-vehicle, industrial control and other fields. The rate can reach 1Mbps. The device provides differential transmit capability to the bus and differential receive capability to the CAN controller.

PARAMETER	SYMBOL	CONDITION	MIN.	MAX.	UNIT
Supply voltage	V_{cc}		4.5	5.5	V
Supply current	I_{cc}	Standby		10	μA
Maximum transmission rate	$1/t_{\text{bit}}$	Non-return to zero code	1		Mbaud
DC voltage on pin CANH and CANL	V_{can}		-40	+40	V
Bus differential voltage	V_{diff}		1.5	3.0	V
Virtual junction temperature	T_{amb}		-40	125	$^{\circ}\text{C}$

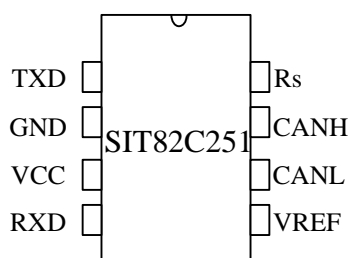
PIN CONFIGURATIO

PIN DESCRIPTION

PIN	SYMBOL	DESCRIPTION
1	TXD	transmit data input
2	GND	ground supply
3	VCC	supply voltage
4	RXD	receive data output; reads out data from the bus lines
5	VREF	reference voltage output
6	CANL	LOW-level CAN bus line
7	CANH	HIGH-level CAN bus line
8	Rs	standby mode control input

LIMITING VALUES

PARAMETER	SYMBOL	VALUE	UNIT
Supply voltage	V_{CC}	-0.3~+7	V
MCU side port	TXD, RXD, VREF, Rs	-0.3~VCC+0.3	V
Voltage range at any bus terminal	CANL, CANH	-40~40	V
Transient voltage on pins CANH, CANL see Fig 7	V_{tr}	-200~+200	V
Storage temperature	T_{stg}	-55~150	°C
Virtual junction temperature	T_j	-40~150	°C
Ambient temperature	T_{amb}	-40~125	°C
Welding temperature range		300	°C
Continuous power consumption	SOP8	400	mW
	DIP8	700	mW

The maximum limit parameters mean that exceeding these values may cause irreversible damage to the device. Under these conditions, it is not conducive to the normal operation of the device. The continuous operation of the device at the maximum allowable rating may affect the reliability of the device. The reference point for all voltages is ground.

DRIVER ELECTRICAL CHARACTERISTICS

PARAMETER	SYMBOL	CONDITION	MIN.	TYP.	MAX.	UNIT
CANH dominant output voltage	$V_{OH(D)}$	$V_I=0V, R_s=0V,$ $R_L=60\Omega,$ Fig 1, Fig 2	2.9	3.4	4.5	V
CANL dominant output voltage	$V_{OL(D)}$		0.8		1.5	V
Bus recessive output voltage	$V_{O(R)}$	$V_I=3V, R_s=0V,$ $R_L=60\Omega,$ Fig 1, Fig 2	2	2.5	3	V
Bus dominant differential output voltage	$V_{OD(D)}$	$V_I=0V, R_s=0V,$ $R_L=60\Omega,$ Fig 1, Fig 2	1.5		3	V
Bus recessive differential output voltage	$V_{OD(R)}$	$V_I=3V, R_s=0V,$ Fig 1, Fig 2	-0.012		0.012	V
		$V_I=3V, R_s=0V,$ NO LOAD	-0.5		0.05	V
Transmitter dominant voltage symmetry	$V_{dom(TX)sym}$	$V_{dom(TX)sym}=V_{CC}-V_{CANH}$ $-V_{CANL}$	-400		400	mV
Transmitter voltage symmetry	V_{TXsym}	$V_{TXsym}=V_{CANH}+V_{CANL}$	$0.9V_{CC}$		$1.1V_{CC}$	V
Common-mode output voltage	V_{OC}	$R_s=0V,$ Fig 8	2	2.5	3	V
Peak-to-peak Common-mode output voltage	ΔV_{OC}			30		mV
Short-circuit output current	I_{OS}	$CANH=-12V,$ $CANL=open,$ Fig 10	-105	-72		mA
		$CANH=12V,$ $CANL=open,$ Fig 10		0.36	1	mA
		$CANL=-12V,$ $CANH=open,$ Fig 10	-1	0.5		mA
		$CANL=12V,$ $CANH=open,$ Fig 10		71	105	mA
Recessive output current	$I_{O(R)}$	$-27V < CANH < 32V$ $0 < V_{CC} < 5.25V$	-2.0		2.5	mA

(Unless specified otherwise, $V_{CC}=5V\pm 10\%$, $-40^\circ C \leq T_{amb} \leq 125^\circ C$, typical in $V_{CC}=+5V$, $T_{amb}=25^\circ C$).

DRIVER SWITCHING CHARACTERISTICS

PARAMETER	SYMBOL	CONDITION	MIN.	TYP.	MAX.	UNIT
Propagation delay time, low-to-high-level output	t_{PLH}	$R_s=0V$, Fig 4	25	65	120	ns
Propagation delay time, high-to-low-level output	t_{PHL}		25	45	90	ns
Differential output signal rise time	t_r			25		ns
Differential output signal fall time	t_f			50		ns
Enable time from standby mode to dominant	t_{EN}	Fig 7			10	μs
Bus wake-up filter time	t_{BUS}		0.7		5	μs

(Unless specified otherwise, $V_{CC}=5V\pm 10\%$, $-40^\circ C \leq T_{amb} \leq 125^\circ C$, typical in $V_{CC}=+5V$, $T_{amb}=25^\circ C$).

RECEIVER ELECTRICAL CHARACTERISTICS

PARAMETER	SYMBOL	CONDITION	MIN.	TYP.	MAX.	UNIT
Positive-going input threshold voltage	V_{IT+}	$R_s=0V$, Fig 5		800	900	mV
Negative-going input threshold voltage	V_{IT-}		500	650		mV
Hysteresis voltage ($V_{IT+} - V_{IT-}$)	V_{HYS}		100	125		mV
High-level output voltage	V_{OH}	$I_O=-2mA$, Fig 6	4	4.6		V
Low-level output voltage	V_{OL}	$I_O=2mA$, Fig 6		0.2	0.4	V
Power-off bus input current	$I_{(OFF)}$	CANH or CANL=5V, Other pin=0V			5	μA
Input capacitance to ground (CANH or CANL)	C_I			13		pF
Differential input capacitance	C_{ID}			5		pF
Input resistance, (CANH or CANL)	R_{IN}	TXD=3V, $R_s=0V$	15	30	40	k Ω

PARAMETER	SYMBOL	CONDITION	MIN.	TYP.	MAX.	UNIT
Differential input resistance	R_{ID}		30		80	$k\Omega$
Input resistance matching	$R_{I_{match}}$	CANH=CANL	-3%		3%	
The range of common-mode voltage	V_{COM}		-12		12	V

(Unless specified otherwise, $V_{CC}=5V\pm 10\%$, $-40^{\circ}C \leq T_{amb} \leq 125^{\circ}C$, typical in $V_{CC}=+5V$, $T_{amb}=25^{\circ}C$).

RECEIVER SWITCHING CHARACTERISTICS

PARAMETER	SYMBOL	CONDITION	MIN.	TYP.	MAX.	UNIT
Propagation delay time, low-to-high-level output	t_{PLH}	$R_s=0V$ or V_{CC} , Fig 6	60	100	130	ns
Propagation delay time, high-to-low-level output	t_{PHL}		45	70	90	ns
RXD signal rise time	t_r			8		ns
RXD signal fall time	t_f			8		ns

(Unless specified otherwise, $V_{CC}=5V\pm 10\%$, $-40^{\circ}C \leq T_{amb} \leq 125^{\circ}C$, typical in $V_{CC}=+5V$, $T_{amb}=25^{\circ}C$).

DEVICE SWITCHING CHARACTERISTICS

PARAMETER	SYMBOL	CONDITION	MIN.	TYP.	MAX.	UNIT
Loop delay 1, driver input to receiver output, Recessive to Dominant	$t_{d(LOOP1)}$	$R_s=0V$, Fig 9	90		190	ns
Loop delay 2, driver input to receiver output, Dominant to Recessive	$t_{d(LOOP2)}$		90		190	ns

(Unless specified otherwise, $V_{CC}=5V\pm 10\%$, $-40^{\circ}C \leq T_{amb} \leq 125^{\circ}C$, typical in $V_{CC}=+5V$, $T_{amb}=25^{\circ}C$).

OVER TEMPERATURE PROTECTION

PARAMETER	SYMBOL	CONDITION	MIN.	TYP.	MAX.	UNIT
Shutdown junction temperature	$T_{j(sd)}$			160		$^{\circ}C$

TXD-PIN CHARACTERISTICS

PARAMETER	SYMBOL	CONDITION	MIN.	TYP.	MAX.	UNIT
HIGH-level input current	$I_{IH}(TXD)$	$V_I=V_{CC}$	-2		2	μA
LOW-level input current	$I_{IL}(TXD)$	$V_I=0$	-50		-10	μA
When $V_{CC}=0V$, current on TXD pin	$I_{O(off)}$	$V_{CC}=0V, TXD=5V$			1	μA
HIGH-level input voltage	V_{IH}		2		$V_{CC}+0.3$	V
LOW-level input voltage	V_{IL}		-0.3		0.8	V
Open voltage on TXD pin	TXD_O		H			logic

(Unless specified otherwise, $V_{CC}=5V\pm 10\%$, $-40^\circ C \leq T_{amb} \leq 125^\circ C$, typical in $V_{CC}=+5V$, $T_{amb}=25^\circ C$).

COMMON-MODE STABILIZATION OUTPUT

PARAMETER	SYMBOL	CONDITION	MIN.	TYP.	MAX.	UNIT
Common-mode stabilization output voltage	V_O	$-500\mu A < I_O < 500\mu A$	$0.3V_{CC}$		$0.7V_{CC}$	V
Leakage current	$I_{O(RS)}$	$R_S=2V,$ $-12V < V_O < 12V$	-5		5	μA

(Unless specified otherwise, $V_{CC}=5V\pm 10\%$, $-40^\circ C \leq T_{amb} \leq 125^\circ C$, typical in $V_{CC}=+5V$, $T_{amb}=25^\circ C$).

SUPPLY CURRENT

PARAMETER	SYMBOL	CONDITION	MIN.	TYP.	MAX.	UNIT
Standby	I_{CC}	$R_S=V_{CC}, V_I=V_{CC}$		5	12	μA
Dominant		$V_I=0V, R_S=0V,$ $LOAD=60\Omega$		50	70	mA
Recessive		$V_I=V_{CC}, R_S=0V,$ $NO\ LOAD$		6	10	mA

(Unless specified otherwise, $V_{CC}=5V\pm 10\%$, $-40^\circ C \leq T_{amb} \leq 125^\circ C$, typical in $V_{CC}=+5V$, $T_{amb}=25^\circ C$).

ESD PERFORMANCE

PARAMETER	SYMBOL	CONDITION	MIN.	TYP.	MAX.	UNIT
CAN bus pin human body discharge model (HBM)	V_{ESD_HBM}		-8		+8	kV

FUNCTION TABLE
Table1.CAN TRANSCEIVER TRUTH TABLE

V _{CC}	TXD ⁽¹⁾	Rs ⁽¹⁾	CANH ⁽¹⁾	CANL ⁽¹⁾	BUS STATE	RXD ⁽¹⁾
4.5V~5.5V	L	L	H	L	Dominate	L
4.5V~5.5V	H or Open	X	0.5V _{CC}	0.5V _{CC}	Recessive	H
4.5V~5.5V	X	H or Open	GND	GND	Recessive	H
0<V _{CC} <4.5V	X	X	0V<V _{CANH} <V _{CC}	0V<V _{CANL} <V _{CC}	Recessive	X

(1) H=high level; L=low level; X=irrelevant.

Table 2. DRIVER FUNCTION TABLE

INPUTS		OUTPUTS		Bus State
TXD ⁽¹⁾	Rs ⁽¹⁾	CANH ⁽¹⁾	CANL ⁽¹⁾	
L	L	H	L	Dominate
H or Open	X	Z	Z	Recessive
X	H or Open	Z	Z	Recessive

(1) H=high level; L=low level; X=irrelevant; Z=high impedance.

Table 3. RECEIVER FUNCTION TABLE

V _{ID} =CANH-CANL	RXD ⁽¹⁾	Bus State ⁽¹⁾
V _{ID} ≥0.9V	L	Dominate
0.5<V _{ID} <0.9V	?	?
V _{ID} ≤0.5V	H	Recessive
Open	H	Recessive

H=high-level; L=low-level; ?=uncertain.

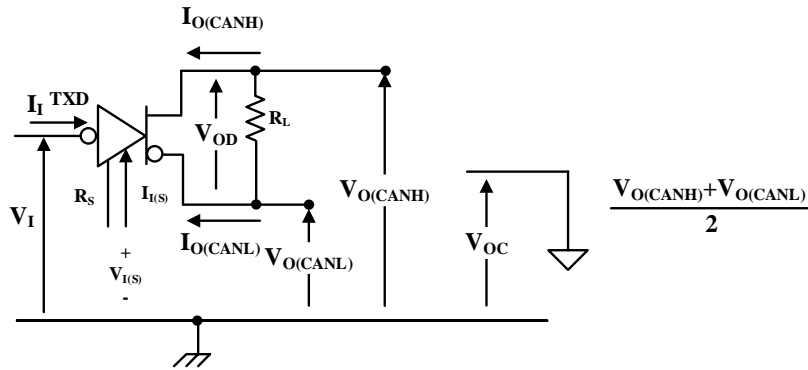
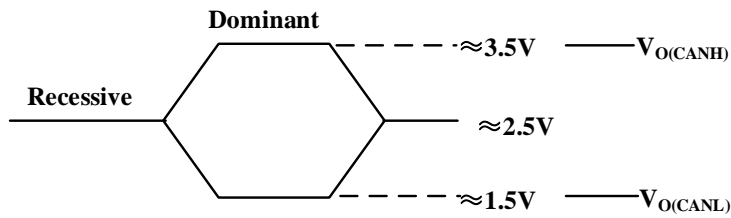
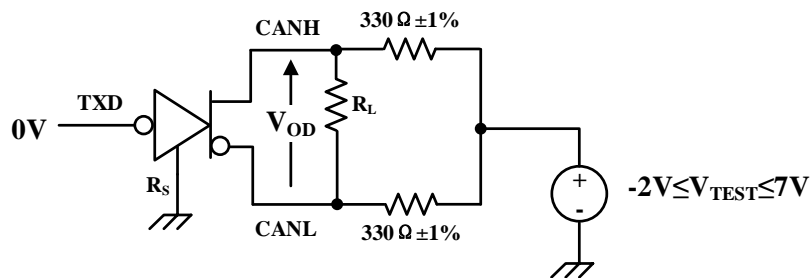
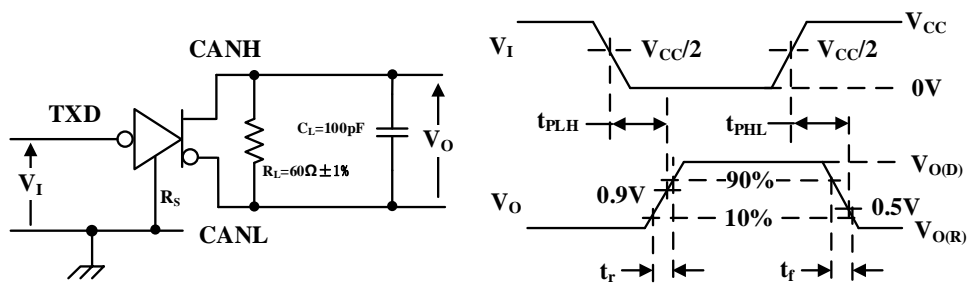
TEST CIRCUIT

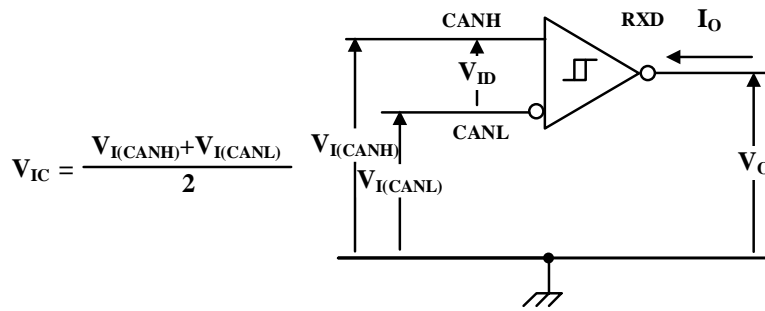
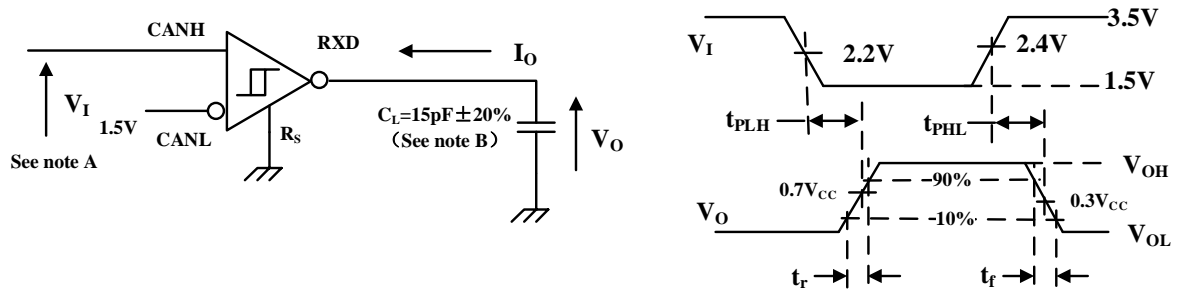
Fig 1 Driver Voltage, Current, and Test Definition

Fig.2 Bus Logic State Voltage Definition

Fig 3 Driver V_{OD} Test Circuit

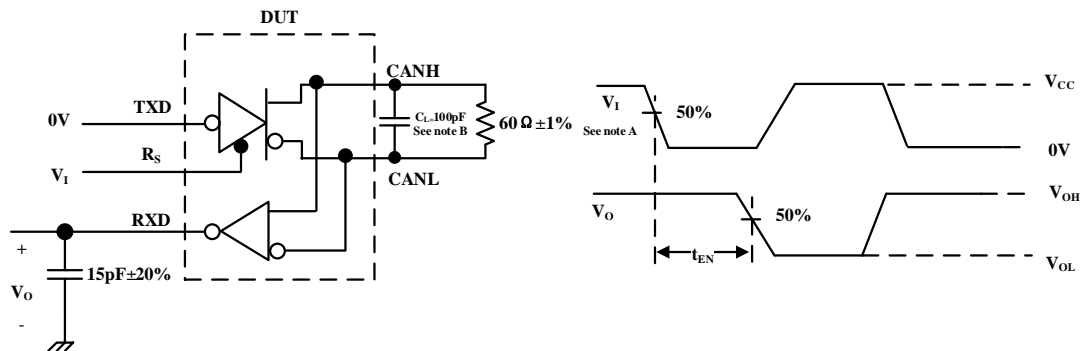
Fig 4 Driver Test Circuit and Waveform

Fig 5 Receiver Voltage and Current Definition

A: The input pulse is supplied by a generator having the following characteristics: $PRR \leq 125$ kHz, 50% duty cycle, $t_r \leq 6$ ns, $t_f \leq 6$ ns, $Z_O = 50 \Omega$.

B: C_L includes instrumentation and fixture capacitance within $\pm 20\%$.

Fig 6 Receiver Test Circuit and Waveform

A: All V_I input pulses are supplied by a generator having the following characteristics: $PRR \leq 25$ kHz, 50% duty cycle, $t_r < 6$ ns, $t_f < 6$ ns;

B: C_L includes instrumentation and fixture capacitance within $\pm 20\%$.

Fig 7 t_{EN} Test Circuit and Waveform

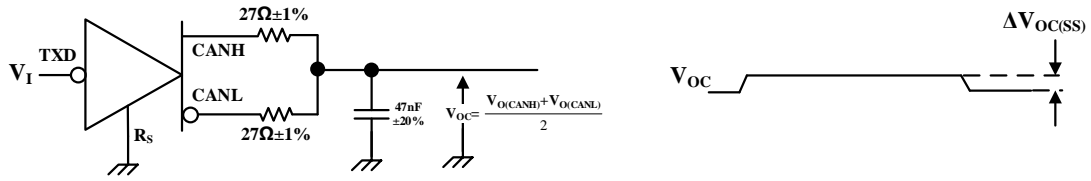

Note: V_I range from 0 to V_{CC} , the input pulse is supplied by a generator having the following characteristics: $PRR \leq 125\text{kHz}$, 50% duty cycle, $t_r < 6\text{ns}$, $t_f < 6\text{ns}$, $Z_o = 50\Omega$.

Fig 8 Peak-to-Peak Common Mode Output Voltage Test and Waveform

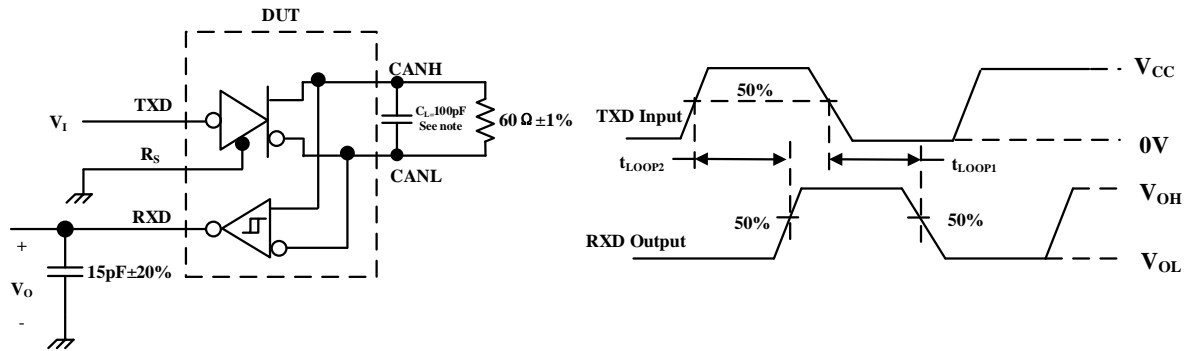

NOTE: C_L includes instrumentation and fixture capacitance within $\pm 20\%$.

Fig 9 $t_{(LOOP)}$ Test Circuit and Waveform

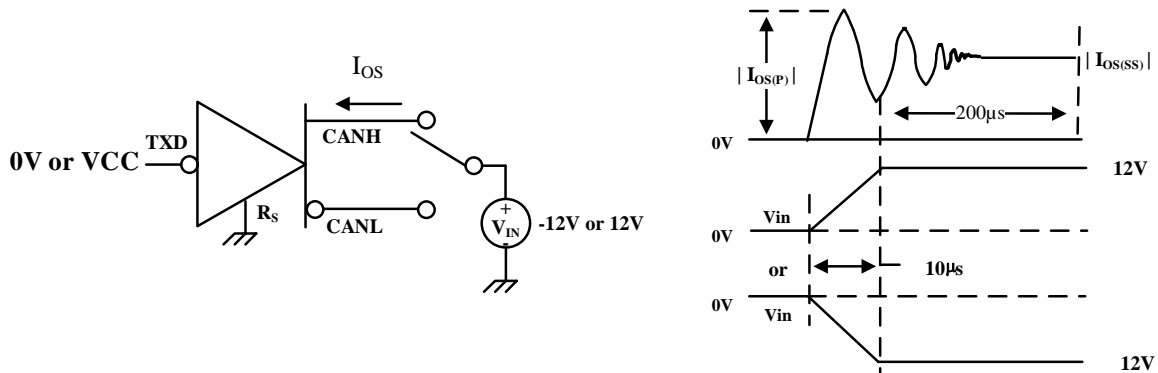

Fig 10 Driver Short-Circuit Current Test Circuit and Waveform

ADDITIONAL DESCRIPTION**1 Sketch**

SIT82C251 is an interface chip applied between the CAN protocol controller and the physical bus. It can be used in in-vehicle, industrial control and other fields. The rate can reach 1Mbps. It has the ability to perform between the bus and the CAN protocol controller. The ability of differential signal transmission is fully compatible with the ISO 11898 standard.

2 Short circuit protection

The driver stage of SIT82C251 has a current-limiting protection function to prevent the driver circuit from being short-circuited to the positive and negative power supply voltages. When a short-circuit occurs, the power consumption will increase. The short-circuit protection function can protect the driver stage from damage.

3 Over temperature protection

SIT82C251 has an over-temperature protection function. When the junction temperature exceeds 160°C, the current of the driver stage will be reduced, because the driver tube is the main energy-consuming part, and the current reduction can reduce the power consumption and thus reduce the chip temperature. At the same time, other parts of the chip are still working normally.

4 Electrical transient protection

Electrical transients often occur in automotive application environments. CANH and CANL of SIT82C251 have the function of preventing electrical transient damage.

5 Control mode

The control pin Rs allows two working modes to be selected:

High-speed mode or low-power standby mode.

The high-speed mode is a normal operating mode and is selected by grounding the pin Rs. The transceiver can send and receive data through the bus CANH and CANL. The differential receiver converts the analog data on the bus into digital data, and outputs it to the pin RXD through a multiplexer (MUX).

If the pin Rs is connected to a high level or not connected, it works in a low-power standby mode. In the low-power standby mode, the transmitter is turned off and the receiver enters a low current state. If the receiver detects the bus dominance (bus differential voltage > 0.9V), RXD switches to low level, the MCU needs to respond to this action at this time, and enter the normal operating state by controlling the Rs pin. Because in the standby state, the current is small and the response time is longer, the first signal may be lost at a higher baud rate.

SOP8 DIMENSIONS
PACKAGE SIZE

SYMBOL	MIN/mm	TYP/mm	MAX/mm
A	1.40	-	1.80
A1	0.10	-	0.25
A2	1.30	1.40	1.50
A3	0.60	0.65	0.70
b	0.38	-	0.51
D	4.80	4.90	5.00
E	5.80	6.00	6.20
E1	3.80	3.90	4.00
e	1.27BSC		
h	0.25	-	0.50
L	0.40	0.60	0.80
L1	1.05REF		
c	0.20	-	0.25
θ	0°	-	8°

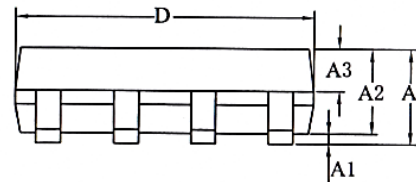
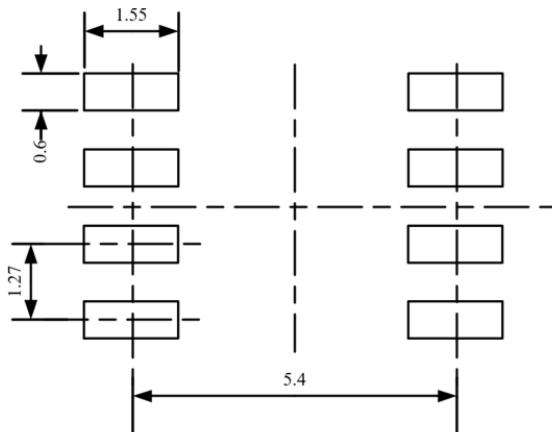
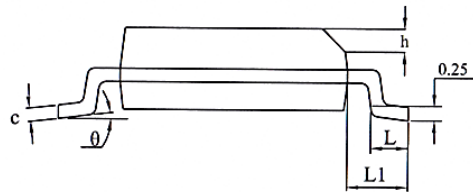
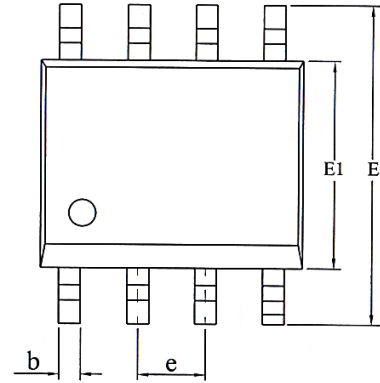

LAND PATTERN EXAMPLE (Unit: mm)

DIP8 DIMENSIONS
PACKAGE SIZE

SYMBOL	MIN/mm	TYP /mm	MAX/mm
A	9.00	9.20	9.40
A1	0.38	0.47	0.57
A2	2.54TYP		
A3	1.524TYP		
B	8.40	8.70	9.10
B1	6.20	6.40	6.60
B2	7.32	7.62	7.92
C	3.20	3.40	3.60
C1	0.50	0.60	0.80
C2	3.71	4.00	4.31
D	0.20	0.28	0.36
L	3.00	3.30	3.60

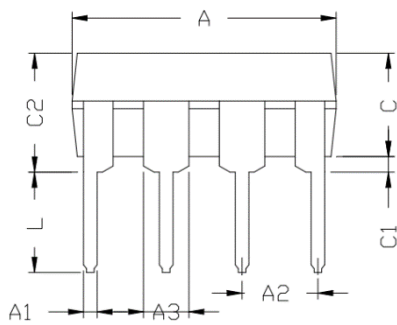
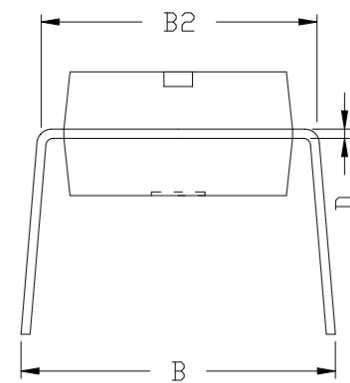
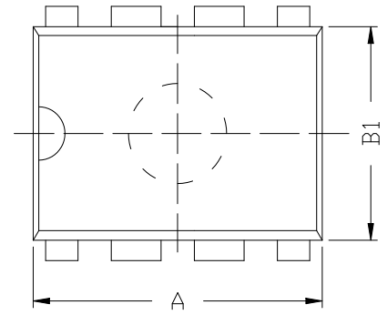

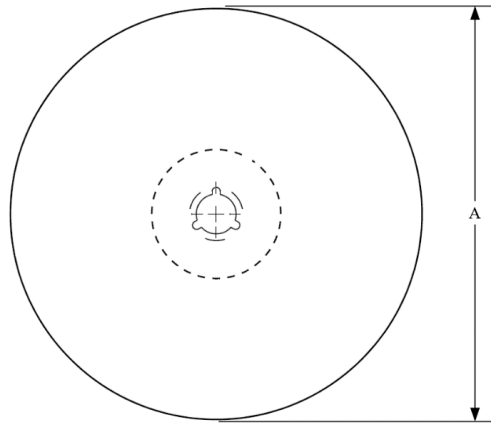
TAPE AND REEL INFORMATION

A0	Dimension designed to accommodate the component width
B0	Dimension designed to accommodate the component length
K0	Dimension designed to accommodate the component thickness
W	Overall width of the carrier tape
P1	Pitch between successive cavity centers

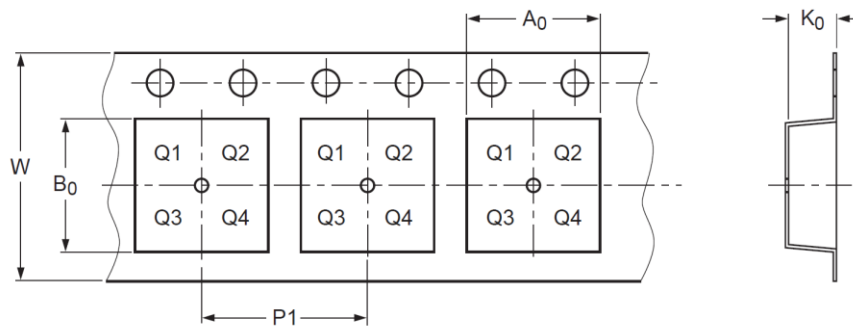
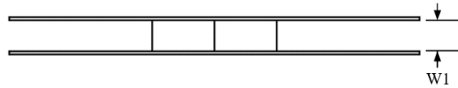

Direction of Feed →

PIN1 is in quadrant 1

Package type	Reel diameter A (mm)	Tape width W1 (mm)	A0 (mm)	B0 (mm)	K0 (mm)	P1 (mm)	W (mm)
SOP8	330±2	12.4±0.40	6.50±0.1	5.30±0.10	2.05±0.1	8.00±0.1	12.00±0.1

ORDERING INFORMATION

Type number	package	packing
SIT82C251T	SOP8	Tape and reel
SIT82C251	DIP8	Tube

SOP8 is packed with 2500 pieces/disc in braided packaging. DIP8 is packed with 50 pieces/tube in tubed packaging.

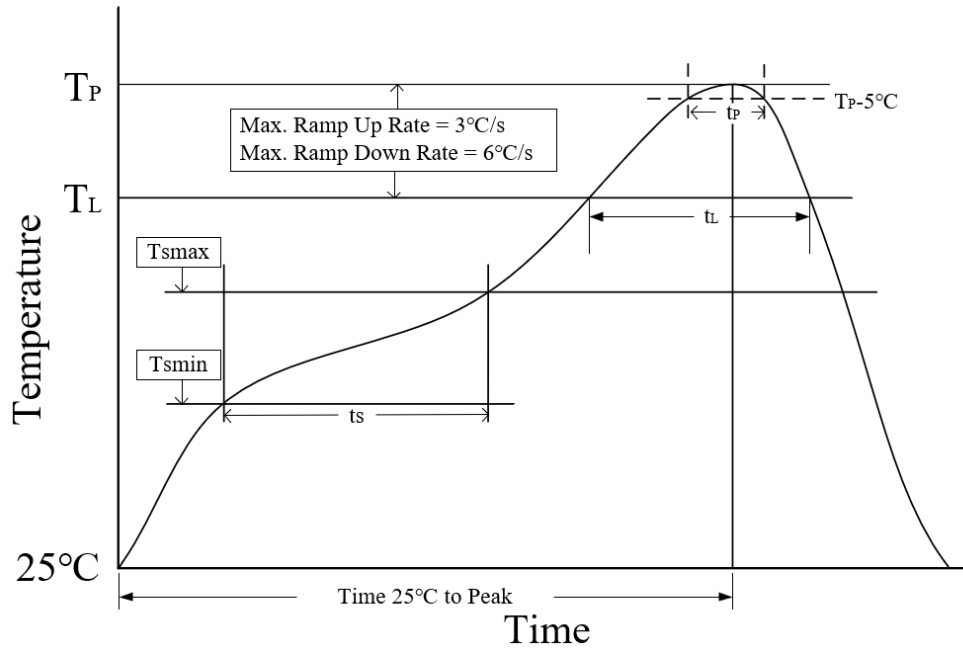
REFLOW SOLDERING

Parameter	Lead-free soldering conditions
Ave ramp up rate (T_L to T_P)	3°C/second max
Preheat time t_s ($T_{smin}=150\text{ °C}$ to $T_{smax}=200\text{ °C}$)	60-120 seconds
Melting time t_L ($T_L=217\text{ °C}$)	60-150 seconds
Peak temp T_P	260-265°C
5°C below peak temperature t_p	30 seconds
Ave cooling rate (T_P to T_L)	6°C/second max
Normal temperature 25°C to peak temperature T_P time	8 minutes max

Important statement

SIT reserves the right to change the above-mentioned information without prior notice.

REVISION HISTORY

Version number	Data sheet status	Revision date
V1.0~V2.3	Product Datasheet.	November 2020
V2.4	Updated SOP8 dimensions; Added important statement.	January 2022
V2.5	Added ESD performance.	April 2022
V2.6	Updated virtual junction temperature range; Updated test circuit; Added tape and reel information; Updated ordering information; Added reflow soldering information; Added revision history.	May 2023
V2.7	Updated <i>Table 1</i> .	September 2024