

FEATURES

- Compatible with the ISO 11898-2:2024, SAE J2284-1 to SAE J2284-5 and SAE J1939-14 standard;
- AEC-Q100 Grade 1 qualified;
- Thermally protected;
- $\pm 58V$ BUS protection;
- $\pm 30V$ bus common mode voltage;
- Driver (TXD) dominant timeout function;
- Silent receive mode;
- SIT1051GQT/3 I/O can be interfaced directly to microcontrollers with supply voltages 1.8V, 3.3V and 5V;
- Undervoltage protection on VCC and VIO power supply pins;
- Timing guaranteed for data rates up to 5 Mbit/s in the (CAN FD) fast phase;
- High Electro-Magnetic Immunity (EMI) and Low Electro-Magnetic Emission (EME);
- Unpowered state disengages from the bus;
- Available in SOP8 and leadless DFN3*3-8 packages; DFN3*3-8 with improved Automated Optical Inspection (AOI) capability.

DESCRIPTION

SIT1051GQ is an interface chip used between the CAN protocol controller and the physical bus. It can be used for in-vehicle, industrial control and other fields. It supports 5Mbps (CAN FD), and has the ability to perform differential signal transmission between bus and the CAN protocol controller.

The SIT1051GQ is fully compatible with the SIT1051Q, SIT1051AQ, and other family products. The SIT1051GQ is an upgraded version with improved EMC performance and lower electromagnetic radiation performance. In addition, the SIT1051GQ can support 1.8V MCU.

PARAMETER	SYMBOL	MIN.	MAX.	UNIT
Bus supply voltage	VCC	4.5	5.5	V
MCU side port supply voltage	VIO	1.7	5.5	V
CANH/CANL input or output voltage	V _{can}	-58	+58	V
Bus differential voltage	V _{diff}	1.5	3.0	V
Ambient temperature	T _{amb}	-40	125	°C
Virtual junction temperature	T _j	-40	150	°C

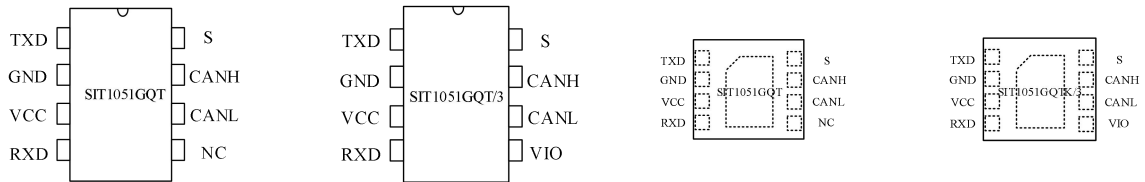
PIN CONFIGURATION

PIN DESCRIPTION

PIN	SYMBOL	DESCRIPTION
1	TXD	transmit data input
2	GND	ground
3	VCC	supply voltage
4	RXD	receive data output
5	VIO	transceiver I/O level conversion power supply voltage (SIT1051GQT/3 and SIT1051GQTK/3 version)
5	NC	Not connected in SIT1051GQT and SIT1051GQTK version
6	CANL	LOW-level CAN-bus line
7	CANH	HIGH-level CAN-bus line
8	S	silent mode control input, low level is high speed mode

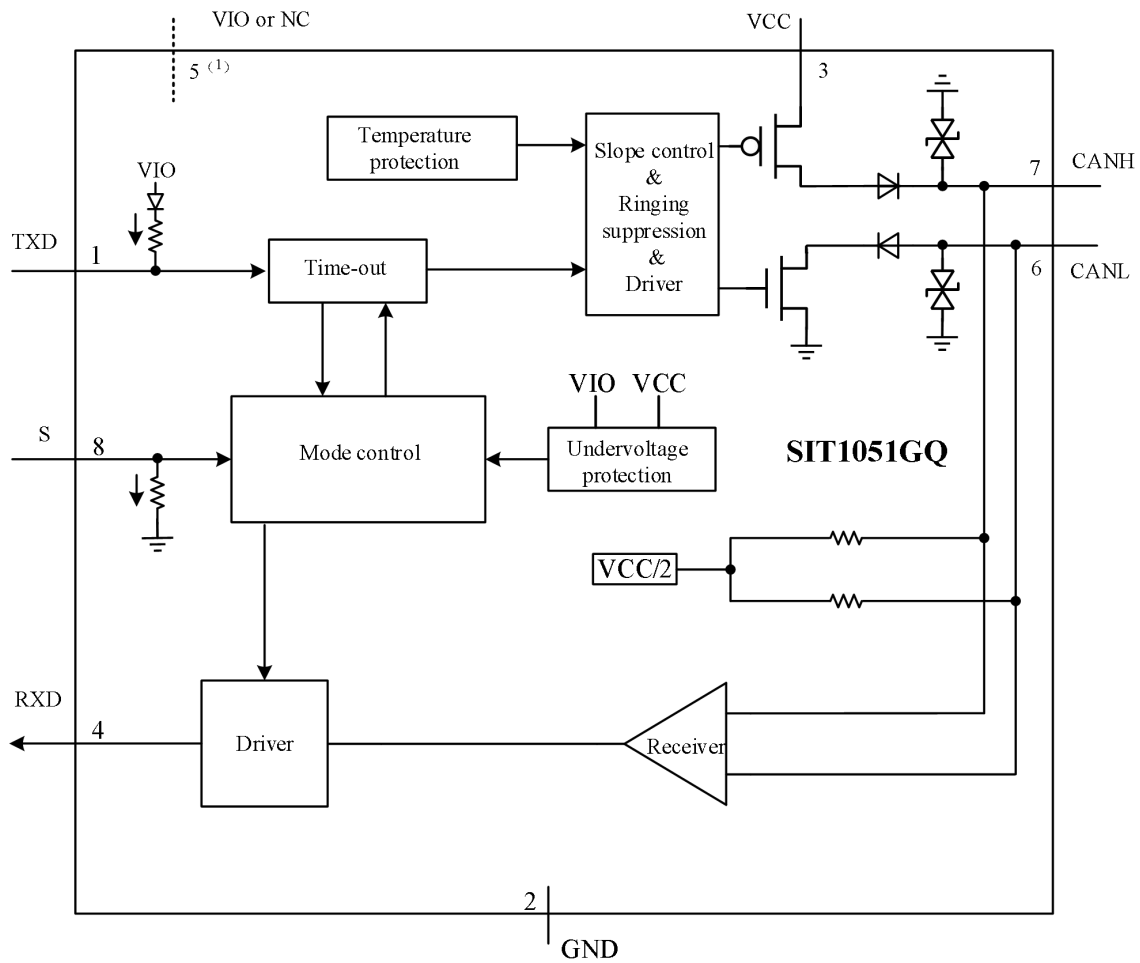
Note: The metal pad on the back of the DFN3*3-8 package is recommended to be grounded.

INTERNAL CIRCUIT BLOCK DIAGRAM

- (1) VIO is only available in SIT1051GQT/3 and SIT1051GQTK/3 version, pin 5 is not connected in SIT1051GQT and SIT1051GQTK version.

LIMITING VALUES

PARAMETER	SYMBOL	CONDITIONS	VALUE	UNIT
Supply voltage	V_{CC}, V_{IO}	pins VCC, VIO	-0.3~+7	V
MCU side port	V_{TXD}, V_{RXD}, V_S	pins TXD, RXD, S	-0.3~+7	V
Bus side input voltage	V_{CANH}, V_{CANL}	pins CANH, CANL	-58~+58	V
Bus differential breakdown voltage	$V_{CANH-CANL}$		-58~+58	V
Storage temperature	T_{stg}		-55~150	°C
Virtual junction temperature	T_j		-40~150	°C

The maximum limit parameters mean that exceeding these values may cause irreversible damage to the device. Under these conditions, it is not conducive to the normal operation of the device. The continuous operation of the device at the maximum allowable rating may affect the reliability of the device. The reference point for all voltages is ground.

THERMAL CHARACTERISTICS

PARAMETER	SYMBOL	CONDITIONS	VALUE	UNIT
$R_{\theta JA}$	Junction-to-ambient thermal resistance	SOP8	95	°C/W
		DFN3*3-8	65	°C/W
$R_{\theta JC}$	Junction-to-case thermal resistance	SOP8	46	°C/W
		DFN3*3-8	35	°C/W

DRIVER ELECTRICAL CHARACTERISTICS

PARAMETER	SYMBOL	CONDITIONS	MIN.	TYP.	MAX.	UNIT
CANH dominant output voltage	$V_{OH(D)}$	Normal mode, $V_{TXD}=0V$, $R_L=50\Omega$ to 65Ω	2.75	3.5	4.5	V
CANL dominant output voltage	$V_{OL(D)}$		0.5	1.5	2.25	V
Bus dominant differential output voltage	$V_{OD(D)}$	Normal mode, $V_{TXD}=0V$, $R_L=50\Omega$ to 65Ω	1.5		3	V
		Normal mode, $V_{TXD}=0V$, $R_L=45\Omega$ to 70Ω	1.4		3.3	V
		Normal mode, $V_{TXD}=0V$, $R_L=2240\Omega$	1.5		5	V
Bus recessive output voltage	$V_{O(R)}$	Normal mode or Silent mode, $V_{TXD}=V_{IO}$, No load	2	$0.5V_{CC}$	3	V
		Normal mode or Silent mode, $V_{TXD}=V_{IO}$, $R_L=60\Omega$	2.2	$0.5V_{CC}$	2.8	V
Bus recessive differential output voltage	$V_{OD(R)}$	Normal mode or Silent mode, $V_{TXD}=V_{IO}$, No load	-50		50	mV
		Normal mode or Silent mode, $V_{TXD}=V_{IO}$, $R_L=60\Omega$	-50		50	mV
Transmitter dominant voltage symmetry	$V_{dom(TX)sym}$	$V_{dom(TX)sym}=V_{CC}-V_{CANH}-V_{CANL}$	-400		400	mV
Transmitter voltage symmetry	V_{TXsym} ⁽¹⁾	$V_{TXsym}=V_{CANH}+V_{CANL}$, $R_L=60\Omega$, $C_{SPLIT}=4.7nF$, $f_{TXD}=250kHz, 1MHz, 2.5MHz$ Figure 5	$0.9V_{CC}$		$1.1V_{CC}$	V
Dominant-recessive common-mode output voltage difference	$V_{cm(step)}$	Figure 3 & Figure 5	-150		150	mV
Dominant-recessive common-mode peak-to-peak	$V_{cm(p-p)}$ ⁽¹⁾	Figure 3 & Figure 5	-300		300	mV
Dominant Short-circuit output current	$I_{O(SC)DOM}$	Normal mode, $V_{TXD}=0V$, $V_{CANH}=-15V$ to $40V$	-100			mA
		Normal mode, $V_{TXD}=0V$, $V_{CANL}=-15V$ to $40V$			100	mA
Recessive Short-circuit output current	$I_{O(SC)REC}$	Normal mode, $V_{TXD}=V_{IO}$, $V_{CANH}=V_{CANL}=-27V$ to $32V$	-3		3	mA

 Unless otherwise stated, all typical values are measured at 25°C, supply voltage $V_{CC}=5V$, $V_{IO}=5V$ (if applicable), $R_L=60\Omega$.

(1) Not tested in production, guaranteed by design.

DRIVER SWITCHING CHARACTERISTICS

PARAMETER	SYMBOL	CONDITIONS	MIN.	TYP.	MAX.	UNIT
Propagation delay time, low-to-high level output	$t_{d(TXD-busdom)}$	Normal mode, Figure 1 & Figure 4			80	ns
Propagation delay time, high-to-low level output	$t_{d(TXD-busrec)}$	Normal mode, Figure 1 & Figure 4			80	ns
Differential output signal rise time	$t_{r(BUS)}$			30		ns
Differential output signal fall time	$t_{f(BUS)}$			30		ns

Unless otherwise stated, all typical values are measured at 25°C, supply voltage $V_{CC}=5V$, $V_{IO}=5V$ (if applicable), $R_L=60\Omega$.

RECEIVER ELECTRICAL CHARACTERISTICS

PARAMETER	SYMBOL	CONDITIONS	MIN.	TYP.	MAX.	UNIT
Receiver threshold voltage	$V_{th(RX)dif}$	Normal mode or silent mode, $-30V < V_{CM} < 30V$	0.5		0.9	V
Receiver threshold voltage hysteresis range	$V_{hys(RX)dif}$	Normal mode or silent mode, $-30V < V_{CM} < 30V$		80		mV
Receiver recessive voltage range	$V_{rec(RX)}$	Normal mode or silent mode, $-30V < V_{CM} < 30V$	-3		0.5	V
Receiver dominant voltage range	$V_{dom(RX)}$	Normal mode or silent mode, $-30V < V_{CM} < 30V$	0.9		8	V
Bus leakage current	I_L	$V_{CC}=V_{IO}=0V$, $V_{CANH}=V_{CANL}=5V$, $T_{amb} < 105^\circ C$	-10		10	μA
CANH, CANL input resistance	R_{IN}	$-2V \leq V_{CANH} \leq 7V$ $-2V \leq V_{CANL} \leq 7V$	25	40	50	k Ω
CANH, CANL differential-input resistance	R_{ID}	$-2V \leq V_{CANH} \leq 7V$ $-2V \leq V_{CANL} \leq 7V$	50	80	100	k Ω
CANH, CANL input	ΔR_{IN}	$0V \leq V_{CANH} \leq 5V$	-2		2	%

PARAMETER	SYMBOL	CONDITIONS	MIN.	TYP.	MAX.	UNIT
resistance mismatch		$0V \leq V_{CANL} \leq 5V$				
CANH, CANL input capacitance to ground	$C_{IN} (\Omega)$	$V_{TXD} = V_{IO}$			40	pF
CANH, CANL differential-input capacitance	$C_{ID} (\Omega)$	$V_{TXD} = V_{IO}$			20	pF

Unless otherwise stated, all typical values are measured at 25°C, supply voltage $V_{CC}=5V$, $V_{IO}=5V$ (if applicable), $R_L=60\Omega$.

(1) Not tested in production, guaranteed by design.

RECEIVER SWITCHING CHARACTERISTICS

PARAMETER	SYMBOL	CONDITIONS	MIN.	TYP.	MAX.	UNIT
Propagation delay time, low-to-high level output	$t_{d(busdom-RXD)}$	Normal mode, Figure 1 & Figure 4			110	ns
Propagation delay time, low-to-high level output	$t_{d(busrec-RXD)}$	Normal mode, Figure 1 & Figure 4			110	ns
RXD signal rise time	$t_{r(RXD)}$			8		ns
RXD signal fall time	$t_{f(RXD)}$			8		ns

Unless otherwise stated, all typical values are measured at 25°C, supply voltage $V_{CC}=5V$, $V_{IO}=5V$ (if applicable), $R_L=60\Omega$.

DEVICE SWITCHING CHARACTERISTICS

PARAMETER	SYMBOL	CONDITIONS	MIN.	TYP.	MAX.	UNIT
Loop delay 1, TXD falling edge to RXD falling edge	t_{loop1}	Normal mode, Figure 1 & Figure 4	40		190	ns
Loop delay 2, TXD rising edge to RXD rising edge	t_{loop2}	Normal mode, Figure 1 & Figure 4	40		190	ns
Bit time of BUS output pin	$t_{bit(BUS)}$	$t_{bit(TXD)}=500ns$	455		510	ns
		$t_{bit(TXD)}=200ns$	155		210	ns
Bit time of RXD output pin	$t_{bit(RXD)}$	$t_{bit(TXD)}=500ns$	420		520	ns
		$t_{bit(TXD)}=200ns$	120		220	ns
Receiver timing symmetry	Δt_{rec}	$\Delta t_{rec} = t_{bit(RXD)} - t_{bit(BUS)}$	-45		15	ns
Received recessive bit width deviation	$\Delta t_{bit(RXD)}$	$\Delta t_{bit(RXD)} = t_{bit(RXD)} - t_{bit(TXD)}$	-80		20	ns
TXD dominant timeout	$t_{dom(TXD)}$		0.8	2	6	ms

Unless otherwise stated, all typical values are measured at 25°C, supply voltage $V_{CC}=5V$, $V_{IO}=5V$ (if applicable), $R_L=60\Omega$.

TXD PIN CHARACTERISTICS

PARAMETER	SYMBOL	CONDITIONS	MIN.	TYP.	MAX.	UNIT
Leakage current of TXD without power	$I_{o(off)}$	$V_{CC}=V_{IO}=0V$, $V_{TXD}=5.5V$	-1		1	μA
HIGH-level input voltage	V_{IH}	SIT1051GQT/3 SIT1051GQTK/3	$0.7V_{IO}$		$V_{IO}+0.3$	V
LOW-level input voltage	V_{IL}	SIT1051GQT/3 SIT1051GQTK/3	-0.3		$0.3V_{IO}$	V
HIGH-level input voltage	V_{IH}	SIT1051GQT SIT1051GQTK	2		$V_{CC}+0.3$	V
LOW-level input voltage	V_{IL}	SIT1051GQT SIT1051GQTK	-0.3		0.8	V
Pull-up resistance	R_{pu}	$2.8V < V_{IO} < 5.5V$	20		80	$k\Omega$
Open voltage on TXD pin	TXD _o		H			logic

Unless otherwise stated, all typical values are measured at 25°C, supply voltage $V_{CC}=5V$, $v_{IO}=5V$ (if applicable), $R_L=60\Omega$.

S PIN CHARACTERISTICS

PARAMETER	SYMBOL	CONDITIONS	MIN.	TYP.	MAX.	UNIT
Leakage current of S without power	$I_{o(off)}$	$V_{CC}=V_{IO}=0V$, $V_S=5.5V$	-1		1	μA
HIGH-level input voltage	V_{IH}	SIT1051GQT/3 SIT1051GQTK/3	$0.7V_{IO}$		$V_{IO}+0.3$	V
LOW-level input voltage	V_{IL}	SIT1051GQT/3 SIT1051GQTK/3	-0.3		$0.3V_{IO}$	V
HIGH-level input voltage	V_{IH}	SIT1051GQT SIT1051GQTK	2		$V_{CC}+0.3$	V
LOW-level input voltage	V_{IL}	SIT1051GQT SIT1051GQTK	-0.3		0.8	V
Pull-down resistance	R_{pd}		20		80	$k\Omega$
Open voltage on S pin	S_o		L			logic

Unless otherwise stated, all typical values are measured at 25°C, supply voltage $V_{CC}=5V$, $V_{IO}=5V$ (if applicable), $R_L=60\Omega$.

RXD PIN CHARACTERISTICS

PARAMETER	SYMBOL	CONDITIONS	MIN.	TYP.	MAX.	UNIT
HIGH-level output current	$I_{OH}(RXD)$	$V_{RXD}=V_{IO}-0.4V$, Bus recessive	-10	-5	-1	mA
LOW-level output current	$I_{OL}(RXD)$	$V_{RXD}=0.4V$, Bus dominant	1	5	10	mA

Unless otherwise stated, all typical values are measured at 25°C, supply voltage $V_{CC}=5V$, $V_{IO}=5V$ (if applicable), $R_L=60\Omega$.

SUPPLY CURRENT

PARAMETER	SYMBOL	CONDITIONS	MIN.	TYP.	MAX.	UNIT
VCC supply current	I_{CC_DOM}	Normal mode, dominant		42	70	mA
	I_{CC_REC}	Normal mode, recessive		5	10	mA
	$I_{CC_DOM_S}$	Dominant; short circuit on bus lines; $-3V < (V_{CANH} = V_{CANL}) < 40V$			109	mA
	I_{CC_S}	Silent mode		2	4	μA
VIO supply current	I_{IO_DOM}	Normal mode or Silent mode TXD=0V		120	240	μA
	I_{IO_REC}	Normal mode or Silent mode TXD=VIO		6	12	μA

Unless otherwise stated, all typical values are measured at 25°C, supply voltage $V_{CC}=5V$, $V_{IO}=5V$ (if applicable), $R_L=60\Omega$.

OVER TEMPERATURE PROTECTION

PARAMETER	SYMBOL	CONDITIONS	MIN.	TYP.	MAX.	UNIT
Shutdown junction temperature	$T_{j(sd)}$ ⁽¹⁾			190		°C

Unless otherwise stated, all typical values are measured at 25°C, supply voltage $V_{CC}=5V$, $V_{IO}=5V$ (if applicable), $R_L=60\Omega$.

(1) Not tested in production, guaranteed by design.

UNDERVOLTAGE PROTECTION

PARAMETER	SYMBOL	CONDITIONS	MIN.	TYP.	MAX.	UNIT
VCC undervoltage protection	V_{UVD_VCC}		3.7		4.3	V
VIO undervoltage protection	V_{UVD_VIO}		1.4		1.65	V

Unless otherwise stated, all typical values are measured at 25°C, supply voltage $V_{CC}=5V$, $V_{IO}=5V$ (if applicable), $R_L=60\Omega$.

FUNCTION TABLE
Table 1 CAN TRANSCEIVER TRUTH TABLE

TXD ⁽¹⁾	S ⁽¹⁾	CANH ⁽¹⁾	CANL ⁽¹⁾	BUS STATE	RXD ⁽¹⁾
L	L or Open	H	L	Dominate	L
H or Open	L or Open	0.5V _{CC}	0.5V _{CC}	Recessive	H
X	H	0.5V _{CC}	0.5V _{CC}	Recessive	H

(1) H=high level; L=low level; X=irrelevant.

Table 2 RECEIVER FUNCTION TABLE

OPERATING MODE	V _{ID} =V _{CANH} -V _{CANL}	BUS STATE	RXD ⁽¹⁾
Normal mode or Silent mode	V _{ID} ≥0.9V	Dominate	L
	0.5< V _{ID} <0.9V	?	?
	V _{ID} ≤0.5V	Recessive	H

(1) H=high level; L=low level; ?=uncertain.

Table 3 UNDERVOLTAGE PROTECTION STATUS TABLE

VCC	VIO ⁽¹⁾	BUS STATE	BUS OUTPUT ⁽²⁾	RXD ⁽²⁾
V _{CC} >V _{uvd_vcc}	V _{IO} >V _{uvd_vio}	Normal	According to S and TXD	Follow the bus
V _{CC} <V _{uvd_vcc}	V _{IO} >V _{uvd_vio}	Protected status	Z	H
V _{CC} >V _{uvd_vcc}	V _{IO} <V _{uvd_vio}	Protected status	Z	Z
V _{CC} <V _{uvd_vcc}	V _{IO} <V _{uvd_vio}	Protected status	Z	Z

(1) SIT1051GQT/3 and SIT1051GQTK/3 version only;

(2) H=high level; Z=high ohmic.

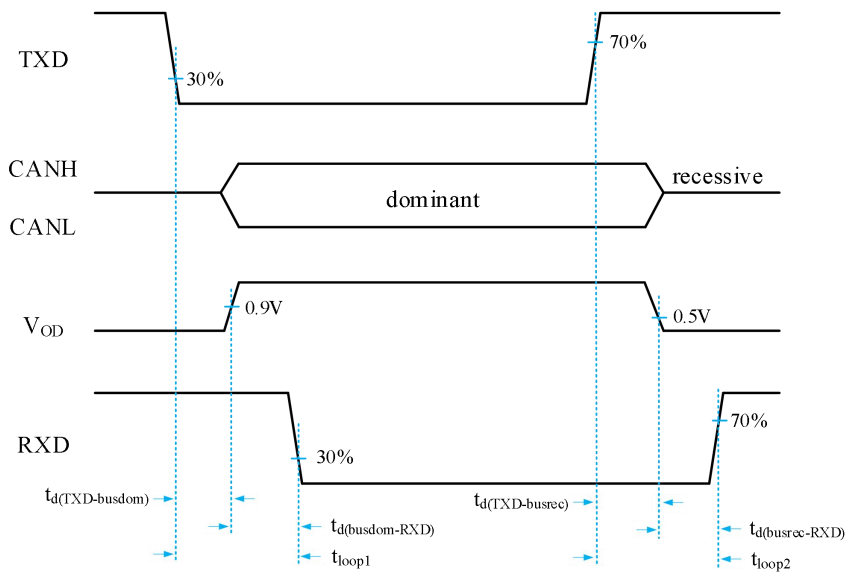
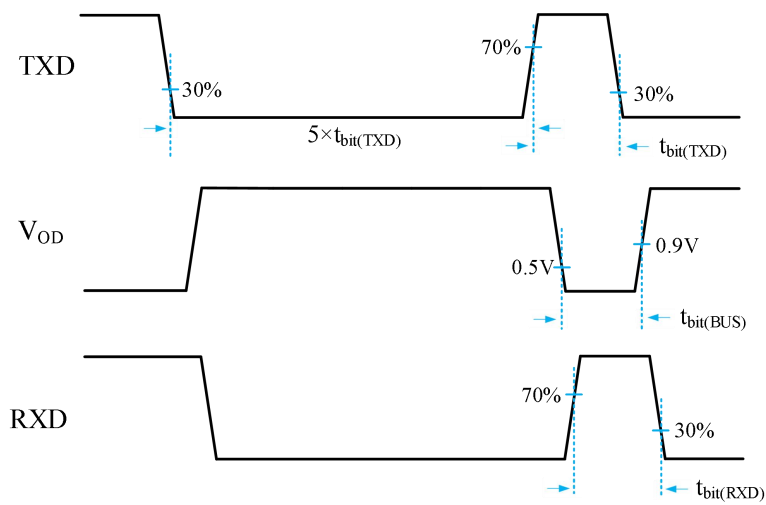
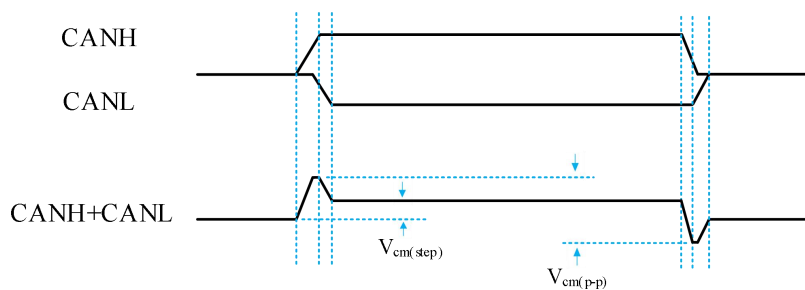
TIMING WAVEFORM

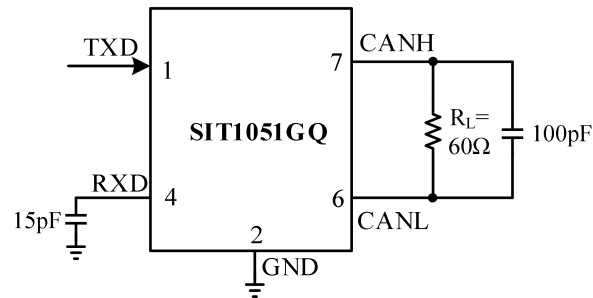
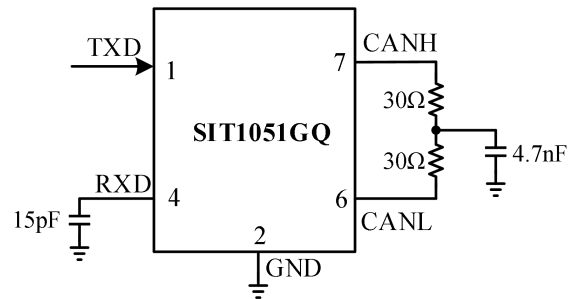
Figure 1 Transceiver transmission delay

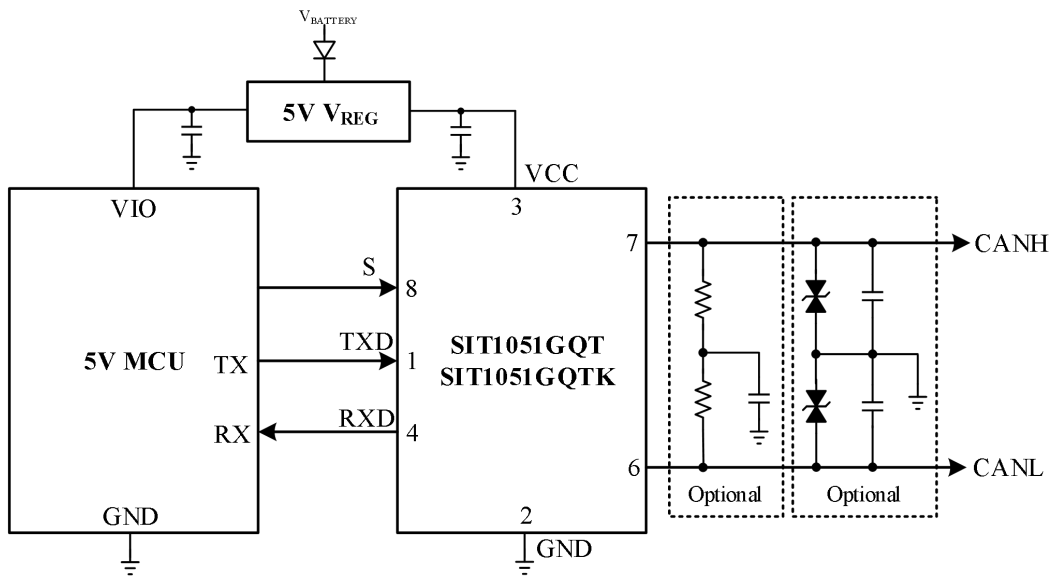
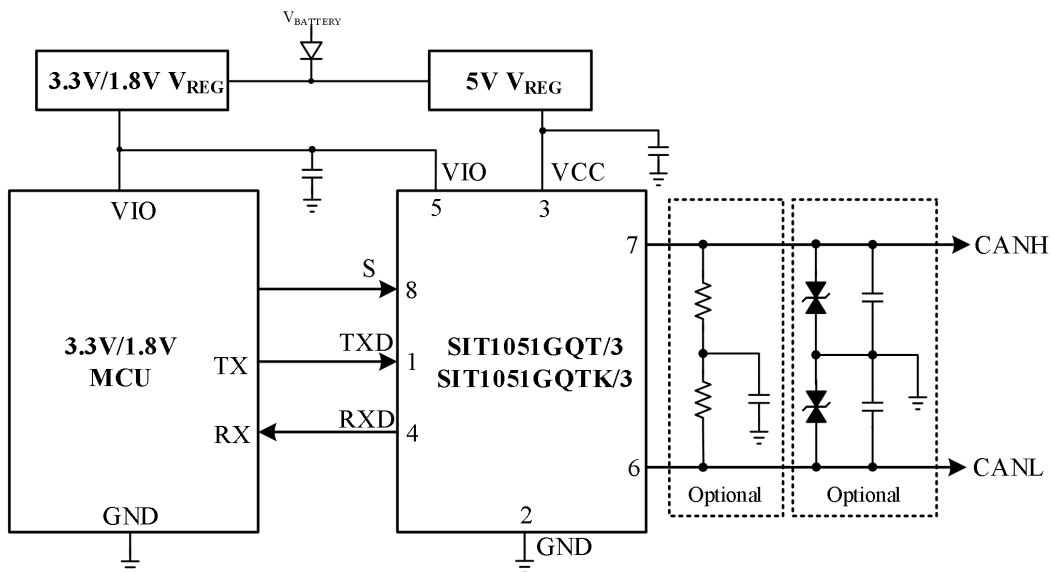
Figure 2 t_{bit} delay

Figure 3 Bus common-mode voltage (SAE 1939-14)

TEST CIRCUIT

Figure 4 Transceiver timing sequence test circuit

Figure 5 Transceiver bus symmetry test circuit

TYPICAL APPLICATION DIAGRAM

Figure 6 SIT1051GQT, SIT1051GQTK and 5V MCU typical application diagram

Figure 7 SIT1051GQT/3, SIT1051GQTK/3 and 1.8V/3.3V MCU typical application diagram

ADDITIONAL DESCRIPTION**1 Sketch**

SIT1051GQ is an interface chip applied between the CAN protocol controller and the physical bus. It can be used for in-vehicle, industrial control and other fields. It supports 5Mbps flexible data rate (CAN FD) and has the ability to transmit differential signals between the bus and the CAN protocol controller. Compatible with ISO 11898-2: 2024 and SAE J2284-1 to SAE J2284-5 standards.

2 Short-circuit protection

A current-limiting circuit protects the transmitter output stage from damage caused by accidental short-circuit to either positive or negative supply voltage, although power dissipation increases during this fault condition.

3 Over temperature protection

The SIT1051GQ features over-temperature protection functionality. When triggered, the current at the driver stage will be reduced since the driver transistor is the primary power-consuming component. This current reduction helps decrease power consumption and consequently lowers the chip temperature. Meanwhile, all other sections of the chip remain fully operational.

4 Undervoltage protection

The SIT1051GQ power supply pin has an undervoltage detection function, which can put the device in a protected mode. This protects the bus when V_{CC} is lower than V_{uvd_VCC} or V_{IO} is lower than V_{uvd_VIO} (if applicable).

5 Control mode

The SIT1051GQ provides two modes of operation which are selectable via pin S: High-speed mode and Silent mode.

High-speed mode is the normal operating mode, selected by grounding or floating the S pin. Both the CAN driver and receiver operate fully normally, enabling bidirectional CAN communication.

Set pin S to high level to activate Silent mode. CAN driver will be shut down, CAN receiver will be activated, and pin RXD will follow the bus.

6 TXD dominant time-out function

A 'TXD dominant time-out' timer circuit prevents the bus lines from being driven to a permanent dominant state (blocking all network communication) if pin TXD is forced permanently LOW by a hardware and/or software application failure. The timer is triggered by a falling edge on pin TXD.

If the duration of the LOW level on pin TXD exceeds the internal timer value (t_{dom}), the transmitter is disabled, driving the bus lines into a recessive state. The timer is reset by a rising edge on pin TXD.

SOP8 DIMENSIONS
PACKAGE SIZE

SYMBOL	MIN./mm	TYP./mm	MAX./mm
A	1.40	-	1.80
A1	0.10	-	0.25
A2	1.30	1.40	1.50
A3	0.60	0.65	0.70
b	0.38	-	0.51
D	4.80	4.90	5.00
E	5.80	6.00	6.20
E1	3.80	3.90	4.00
e	1.27BSC		
L	0.40	0.60	0.80
L1	1.05REF		
c	0.20	-	0.25
θ	0°	-	8°

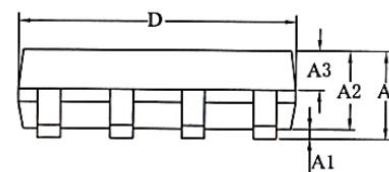
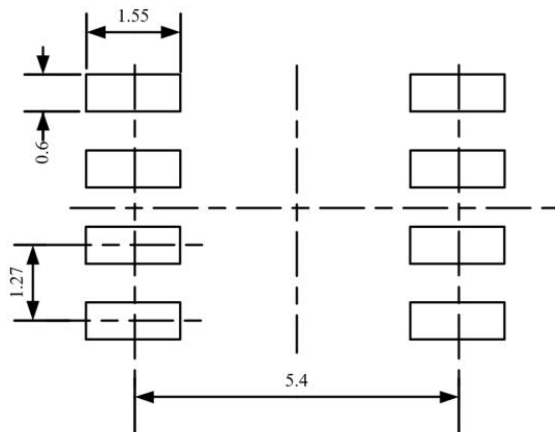
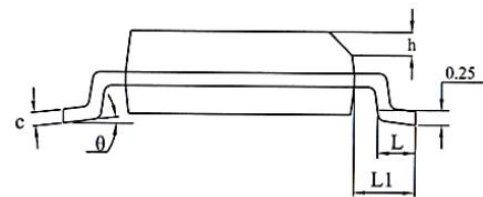
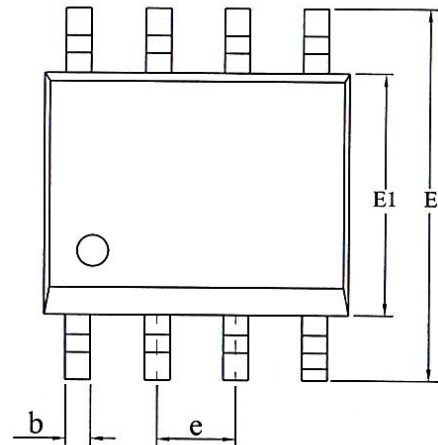

LAND PATTERN EXAMPLE (Unit: mm)

DFN3*3-8 DIMENSIONS
PACKAGE SIZE

SYMBOL	MIN/mm	TYP/mm	MAX/mm
A	0.70	0.75	0.80
A1	0	0.02	0.05
A3	0.203 REF		
D	2.90	3.00	3.10
E	2.90	3.00	3.10
D2	2.05	2.15	2.25
Nd	1.95BSC		
E2	1.10	1.20	1.30
b	0.25	0.30	0.35
e	0.65 TYP		
k	0.50REF		
L	0.35	0.4	0.45
h	0.20	0.25	0.30

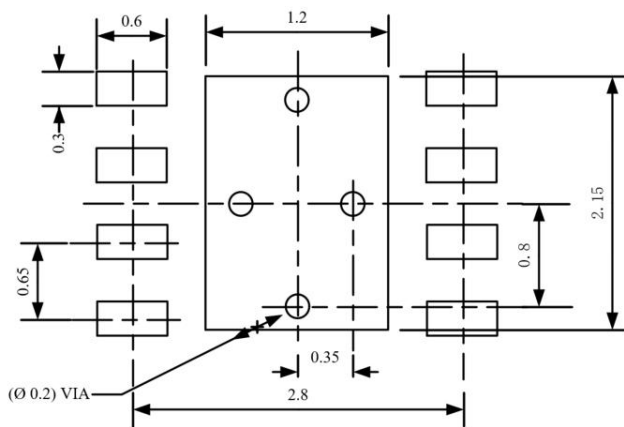
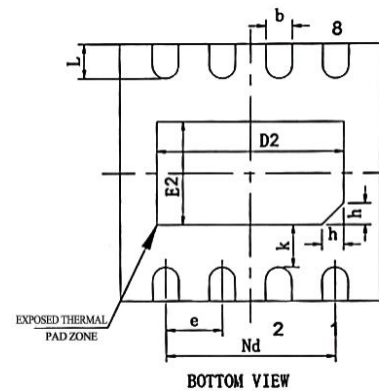
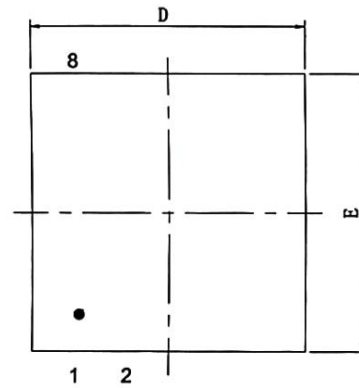

LAND PATTERN EXAMPLE (Unit: mm)

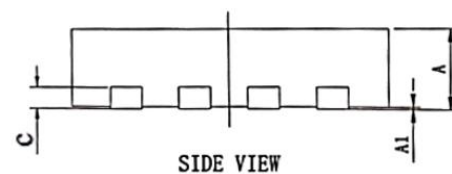

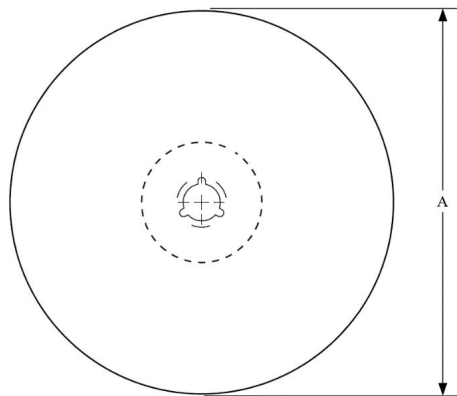
TAPE AND REEL INFORMATION

A0	Dimension designed to accommodate the component width
B0	Dimension designed to accommodate the component length
K0	Dimension designed to accommodate the component thickness
W	Overall width of the carrier tape
P1	Pitch between successive cavity centers

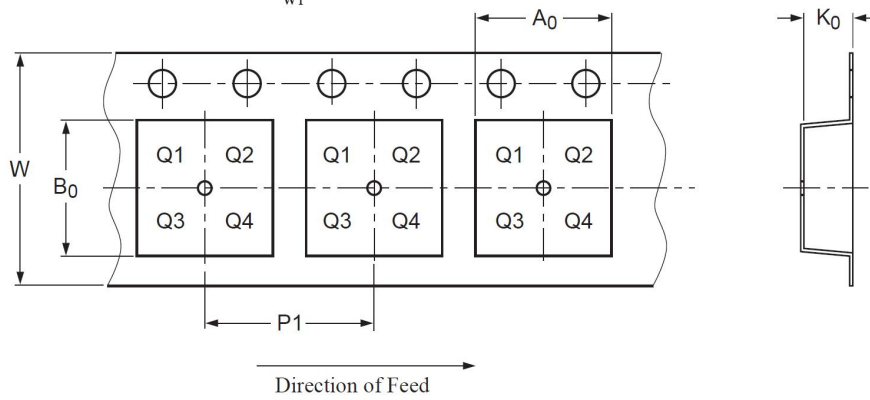
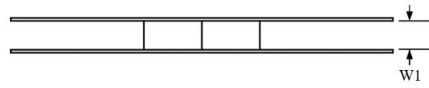

PIN1 is in quadrant 1

Package Type	Reel Diameter A (mm)	Tape Width W1 (mm)	A0 (mm)	B0 (mm)	K0 (mm)	P1 (mm)	W (mm)
SOP8	330±1	12.4	6.60±0.1	5.30±0.10	1.90±0.1	8.00±0.1	12.00±0.1
DFN3*3-8	329±1	12.4	3.30±0.1	3.30±0.1	1.10±0.1	8.00±0.1	12.00±0.3

ORDERING INFORMATION

Type number	Package	MSL	Packing
SIT1051GQT	SOP8	MSL3	Tape and reel
SIT1051GQT/3	SOP8	MSL3	Tape and reel
SIT1051GQTK	DFN3*3-8, small shape, no leads, 8 terminals	MSL1	Tape and reel
SIT1051GQTK/3	DFN3*3-8, small shape, no leads, 8 terminals	MSL1	Tape and reel

SOP8 is packed with 2500 pieces/disc in braided packaging. Leadless DFN3*3-8 is packed with 6000 pieces/disc in braided packaging.

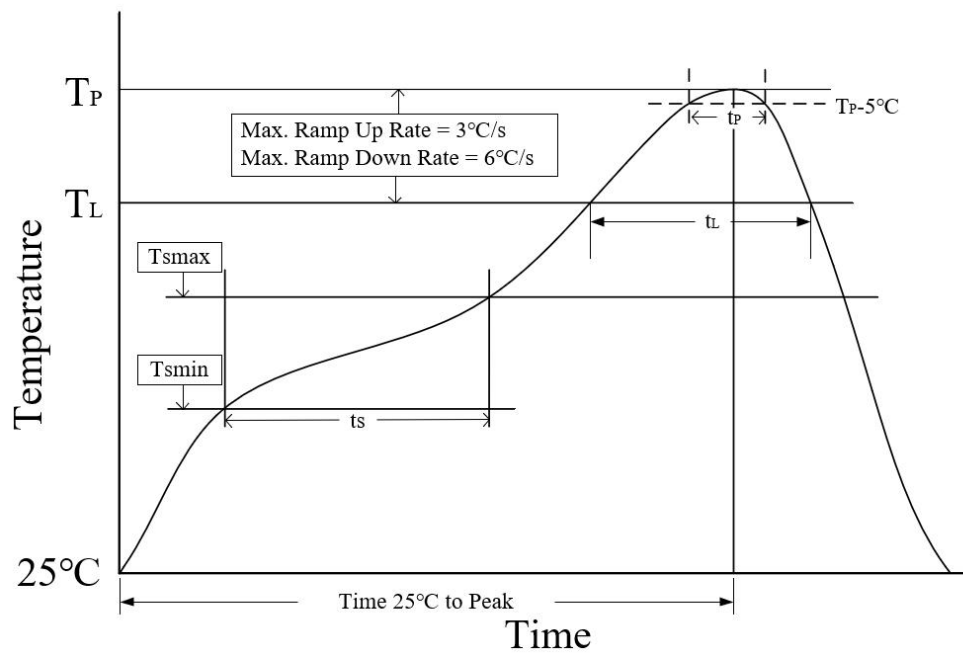
REFLOW SOLDERING

Parameter	Lead-free soldering conditions
Ave ramp up rate (T_L to T_P)	3 °C/second max
Preheat time t_s ($T_{smin}=150^\circ\text{C}$ to $T_{smax}=200^\circ\text{C}$)	60-120 seconds
Melting time t_L ($T_L=217^\circ\text{C}$)	60-150 seconds
Peak temp T_P	260-265 °C
5°C below peak temperature t_p	30 seconds
Ave cooling rate (T_P to T_L)	6 °C/second max
Normal temperature 25°C to peak temperature T_P time	8 minutes max

Important statement

SIT reserves the right to change the above-mentioned information without prior notice.

REVISION HISTORY

Version number	Data sheet status	Revision Date
V1.0	Initial version.	March 2026